

Valve amplifier for proportional valves without electrical position feedback; Maximum current limitation 1 A

Type VT-MSPA2...1A0



- ▶ Component series 2X
- ▶ Easy valve selection of the Rexroth valves for industrial hydraulics
- ▶ Characteristic curves of the valves stored in the device
- ▶ Valve optimization via push-buttons
- ▶ All valve parameters adjustable
- ▶ For explosion-protected valves with one or two solenoids



Features

- ▶ Not in accordance with the Explosion Protection Directive 2014/34/EU
- ▶ Command value input 0 ... ±10 V
- ▶ Reverse polarity protection of the operating voltage
- ▶ Ramp generator up and down is separately adjustable
- ▶ Zero point setting
- ▶ Command value adjustment
- ▶ Characteristic curve generator
- ▶ Clocked power output stage
- ▶ Output short-circuit-proof
- ▶ LED status displays
- ▶ Measuring sockets for actual current value, internal current command/setting

Contents

Features	1
Ordering codes	2
Function	3
Block diagram	4
Technical data	5, 6
Dimensions	7
Status description LEDs	8
Accessories	8
Project planning and maintenance instructions	9
Further information	9

Function

General

The valve amplifiers are intended for assembly on top hat rails. The electrical connection is established via 3 tension spring plug-in connectors. The supply voltage is 24 VDC.

Power supply unit (1)

The internal power supply unit has a making current limiter to prevent current peaks. Additionally, inverse-polarity protection is integrated.

Command value, command value summing device (3)

The "internal command value" comprises:

- ▶ "External command value", connected at the input of the differential amplifier (2)
- ▶ Zero point offset (4), "Z/B" adjustable in the standard setup

For pressure valves, a positive command value results in a pressure increase at the valve.

For valve types 4W..., the following applies:

- ▶ Via solenoid B, a command value of 0 ... +10 V results in a flow in the valve from P to A and from B to T.
- ▶ Via solenoid A, a command value of 0 ... -10 V results in a flow in the valve from P to B and from A to T. In the expert setup, you can invert the command value (5) (see operating instructions 30232-01-B).
- ▶ In normal operation, the "internal command value" can be measured at the "v" measuring socket.

Ramps

A ramp limits the incline of the command value.

You can choose between a single ramp (6) (one time for all ramps, default value) and a 4Q/2Q ramp (7) (different times for the possible ramps). The 4Q/2Q ramp times are set in the expert setup. The characteristic curve generator (9) does not influence the ramp time.

Command value attenuator "G" (8)

By means of the command value attenuator, the command value can be reduced.

Characteristic curve generator (9)

In the characteristic curve generator, the pre-set valve characteristic curve can be adjusted to the actual hydraulic and control-technical conditions.

The following can be adjusted in the expert setup:

- ▶ Pilot current "B"
- ▶ Step "S"
- ▶ Maximum current "G" (separately possible for solenoid A and B)

Current controller (10)

The solenoid current is recorded, compared to the command value in the current controller and the difference is compensated.

Clock generator (11)

The clock generator creates the clock frequency "f" of the output stage. With Rexroth valves, the clock frequency sometimes changes dependent on the command value and/or the operating voltage.

Power output stage (12)

The power output stage creates the clocked solenoid current for the proportional valve. The solenoid current is limited to the maximum admissible current per output, depending on the set valve. The output stages are short-circuit-proof. With an internal interference signal or in case enable is missing, the output stage will be switched off.

Digital input (13)

The input DI can be set to four different functions:

- ▶ 1. Enable (factory setting)
- ▶ 2. Command value inversion (permanent enable)
- ▶ 3. Ramp on/off (permanent enable)
- ▶ 4. Single or quadrant ramp (permanent enable)

Digital output (15)

Device notifies ready for operation if there is no cable break, no internal error and $U_B \geq U_{B \min}$.

See also "block diagram", on page 4.

Block diagram

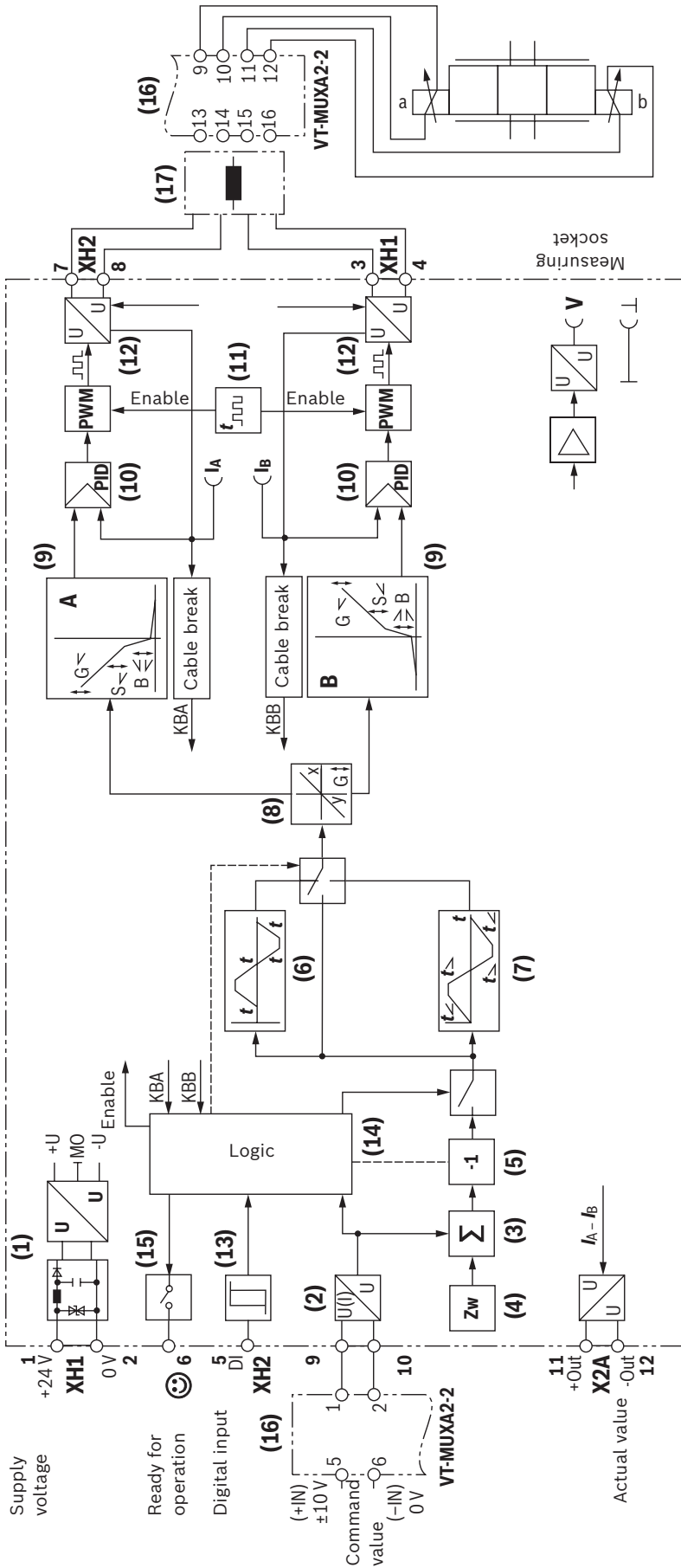

- | | |
|---|--|
| <ul style="list-style-type: none"> 1 Power supply unit 2 Differential amplifier 3 Command value summing device 4 Zero point setting 5 Inverter 6 Single ramp 7 4-quadrant ramp | <ul style="list-style-type: none"> 8 Command value attenuator 9 Characteristic curve generator 10 Current controller 11 Clock generator 12 Output stage 13 Enable or inverter or ramp off or 4Q ramp 14 Switching logics/fault recognition 15 Digital output 16 Monitoring module VT-MUXA2-2 (separate order) 17 Two ferrite sleeves (included in the scope of delivery of the monitoring module only) |
|---|--|

See also "Function" on page 3.

Technical data

General			
Component series			2X
Design			Module
Voltage supply			
Operating voltage	▶ Nominal	V	24; +40% ... -20%
	▶ Lower limit value ¹⁾	V	18
	▶ Upper limit value	V	36
	▶ Maximum admissible residual ripple (40 ... 400 Hz)	V _{pp}	2.5 (observe the admissible limits)
Maximum power consumption		W	< 48
Maximum current consumption		A	< 2
Maximum switch-on current		A	< 4
External fuse		A	3.15 time-lag
Analog input			
Command value	▶ 2 solenoids (0 ... ±100%)	mA	0 ... ±10
	▶ Voltage (differential input)	kΩ	200 (input resistance)
Analog output			
Solenoid current ²⁾	▶ I _A	V	0 ... -2.5 (mV ≙ mA)
	▶ I _B	V	0 ... 2.5 (mV ≙ mA)
	▶ Minimum load impedance	Ω	1000
Digital input			
On (active) ³⁾		V	11 ... U _B
Off (inactive)		V	-3 ... 5
Solenoid outputs			
Maximum solenoid current		A	1.0
Clock frequency-setting range ⁴⁾		Hz	95 ... 505
Other properties, solenoid output			Short-circuit-proof, clocked
Cable length for 1.5 mm ²		m	50
Adjustment options			
Zero point calibration		%	± 10
Command value attenuator ⁵⁾		%	70 ... 110
Ramp time up / down		s	0.01 ... 30
Step level		%	0 ... 50
Measuring sockets			
Command value/setting	▶ "v"	V	0 ... ±10
Actual current value	▶ I _A	V	0 ... ±2.5 (mV ≙ mA)
	▶ I _B	V	0 ... ±2.5 (mV ≙ mA)
Reference potential	▶ "⊥"		
Additional notices			See operating instructions 30232-01

¹⁾ For valves with a maximum solenoid current of 0.8 A, the lower limit value is 21 V

²⁾ Maximum value depending on the selected valve

³⁾ R_E > 50 k

⁴⁾ Depending on the selected valve

⁵⁾ Applies to a command value of 100%

Technical data

Supplementary information			
Start-up time	s	< 1	
Type of connection		12 spring-type terminals, detachable	
Protection class according to EN 60529		IP 20	
Ambient temperature range	°C	0 ... +60	
Weight	kg	0.14	
Maximum admissible temperature change	°C/min	5	
Transport temperature range	°C	-40 ... +70	
Recommended storage temperature with UV protection	°C	+5 ... +40	
Relative air humidity (without condensation)	%	10 ... 95	
Maximum altitude for use	m	2000	
UV resistance		Housing is only partly UV resistant. Extended exposure to radiation may cause color changes.	
Transport shock according to DIN EN 60068-2-27		15 g / 11 ms / 3 axes	
Sine test according to DIN EN 60068-2-6	Hz	10 ... 500 (maximum 2 g / 10 cycles / 3 axes)	
Noise test according to DIN EN 60068-2-64	Hz	20 ... 500 (2.2 g RMS / 6.6 g peak / 30 min. / 3 axes)	
Free fall (in original packaging)	m	1	
Installation position		Vertical. For breathing of the assembly, the ventilation slots of the top and bottom side must be at least 2 cm away from covers, walls, etc. With an ambient temperature of more than 50°C, the clearance to the next assembly must be 1 cm.	
Top hat rail assembly		TH35-7.5 or TH35-15 according to EN 60715	
Housing material		Glass-fiber reinforced polyamide plastic	
Resistance against aggressive media		Contact with conductive dusts is not admissible. Avoid contact with hydraulic fluids.	
Conformity		CE according to the EMC directive CE according to the RoHS directive	
Electro-magnetic compatibility (EMC)	▶ EN 61000-6-2		
	– EN 61000-4-2 ESD	kV	4 kV CD / 8 kV AD with BWK B
	– EN 61000-4-3 HF radiated	V/m	10 (80 ... 6000 MHz) with BWK A
	– EN 61000-4-4 Burst	kV	2 (5 kHz and 100 kHz) with BWK B
	– EN 61000-4-5 Surge	kV	0.5 (2 Ω /12 Ω) to operating voltage, 1 kV (42 Ω) to signal with BWK B
	– EN 61000-4-6 HF conducted	V _{eff}	10 (150 kHz ... 80 MHz) with BWK A
	– EN 61000-4-8 Magnetic field 50/60 Hz	A/m	100 with BWK A
	▶ EN 61000-6-3 / EN 61000-6-4		
	– EN 55016-2-1 Interference voltage	MHz	0.15 ... 30 (class A, EN 55022)
– EN 55016-2-3 Radio interference field strength	MHz	30 ... 6000 (class B, EN 55022)	

Dimensions

(dimensions in mm)

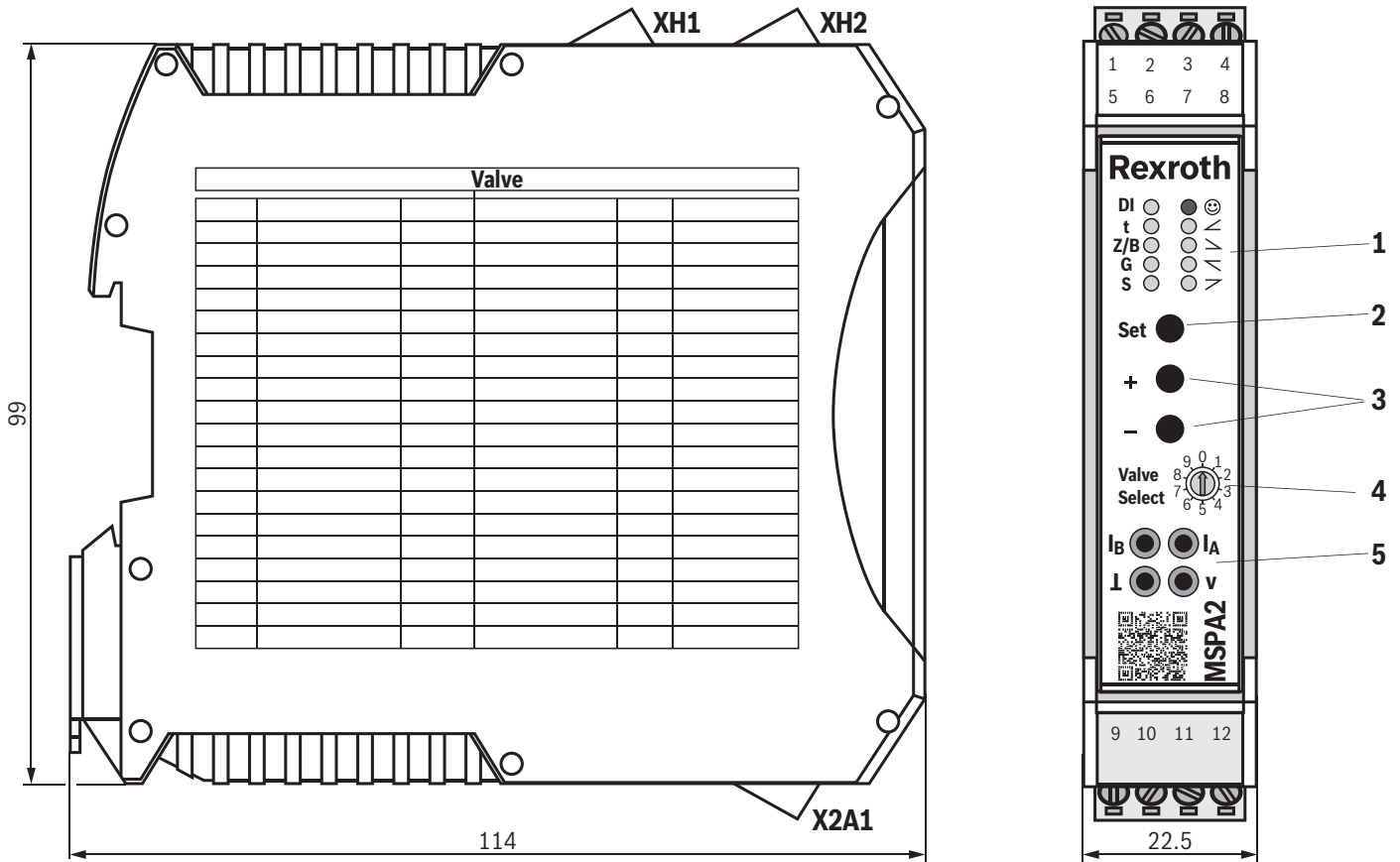

1 Status LEDs

Display the current operating state, menu levels and error conditions

2 SET key

Editing the selected parameters, selection of work operation, selection of the "expert mode"

3 + / - keys

Selection of the parameters and adjustment of the parameter values

4 Rotary switch

Valve type selection

5 Measuring sockets for connecting a measuring instrument

Assignment: Switch position/valve type

Switch position	Valve type
0	No valve
1	DBET...6X...XE
2	4WRA 6...XE
3	3DREP 6...XE
4	4WRZ...XE
9	Universal

Terminal assignment

Assignment		Connector	Terminal
Operating voltage	+U _B	XH1	1
	0 V	XH1	2
+ solenoid B		XH1	3
- solenoid B		XH1	4
Digital input		XH2	5
Ready		XH2	6
+ solenoid A		XH2	7
- solenoid A		XH2	8
+ command value		X2A	9
- command value		X2A	10
+ actual value		X2A	11
- actual value		X2A	12

Status description LEDs

Indicator light	Operating state	Display mode	Meaning
"Digital input" LED (yellow)	Normal operation	Permanent light on/off	Digital input status
	Setup	Flashing	Standard setup active
	Setup	Off	Expert setup active
	Setup	On/flashing/flickering	Expert setup: Digital input setting
"Ready" LED (red/green)	Normal operation	Permanent light, green	Module ready for operation
	Normal operation	Permanent light, red	Error
	Normal operation and setup	Flashing light, red-green	Valve setting changed
	Normal operation and setup	Flashing light, red	Inadmissible valve number
	Normal operation	Off	Module not ready for operation
	Setup	Flashing light, green	Expert setup active

Description of the LED display ¹⁾	
DI	Enable ²⁾
t	Ramp
Z/B	Zero point / pilot current
G	Command value attenuator
S	Step level command value
☺	Ready for operation
∠	1st quadrant (positive command value rising)
∩	2nd quadrant (positive command value falling)
∟	3rd quadrant (negative command value rising)
∩	4th quadrant (negative command value falling)

¹⁾ A detailed description is contained in the operating instructions 30232-01-B

²⁾ Function of the digital input can be adjusted in the setup

Accessories (separate order)

	Material no.
Shield set for the installation with shielded lines	R961011117

Project planning and maintenance instructions

Project planning information:

- ▶ To comply with the safety requirements for the operation of the valve in potentially explosive atmospheres, it must be ensured that the solenoid current does not exceed 1 A. For monitoring and limitation of the valve flow, we recommend using the Rexroth monitoring module VT-MUXA2-2, see data sheet 30290.
- ▶ The VT-MSPA2-2X...1A0 valve amplifier and the VT-MUXA2-2 monitoring module may only be installed outside the potentially explosive atmosphere.
- ▶ The VT-MSPA2-2X...1A0 valve amplifier and the VT-MUXA2-2 monitoring module are not subject to directive 2014/34/EU.

Maintenance instructions:

- ▶ The devices have been tested in the plant and are supplied with default settings.
- ▶ Only complete devices can be repaired.
- ▶ Repaired devices are returned with default settings. User-specific settings must be made by the machine end-user once again.

Notice:

- ▶ In especially EMC-sensitive environments, additional measures must be taken (depending on the application, e.g. shielding, filtration)
- ▶ **Wiring information**
 - Maximum possible spatial separation between signal and load lines.
 - Do not lead signal lines through magnetic fields.
 - If possible, install signal lines without intermediate terminals.
 - Do not install signal lines in parallel to the load lines.
 - Connect cable shields (see operating instructions 30232-01-B)
 - For digital inputs and outputs as well as command and actual value, the max. admissible cable length for unshielded cables is 30 m. For longer cable lengths, shielded cables must be used.
 - The distance to radios must be sufficient (> 1 m).
 - With a strongly fluctuating operating voltage, in individual cases, it may be necessary to use an external smoothing capacitor with a capacity of at least 2200 µF.
- ▶ Recommendation: capacitor module VT 11110 (see data sheet 30750); sufficient for up to 3 amplifier modules.
- ▶ The upper and lower ventilation slots must not be concealed by adjacent devices in order to provide for sufficient cooling.

Further information

- | | |
|--|-----------------------------------|
| ▶ Valve amplifier for proportional valves without electrical position feedback | Operating instructions 30232-01-B |
| ▶ CE Declaration of Conformity | upon request |
| ▶ Installation, commissioning and maintenance of proportional valves | Data sheet 07800 |
| ▶ Assembly, commissioning and maintenance of hydraulic systems | Data sheet 07900 |

Notes

Bosch Rexroth AG
Industrial Hydraulics
Zum Eisengießer 1
97816 Lohr am Main, Germany
Phone +49 (0) 93 52/40 30 20
my.support@boschrexroth.de
www.boschrexroth.de

© All rights reserved to Bosch Rexroth AG, also regarding any disposal, exploitation, reproduction, editing, distribution, as well as in the event of applications for industrial property rights.
The data specified above only serve to describe the product. No statements concerning a certain condition or suitability for a certain application can be derived from our information. The information given does not release the user from the obligation of own judgment and verification.
Please note that our products are subject to a natural process of wear and aging.

Notes

Bosch Rexroth AG
Industrial Hydraulics
Zum Eisengießer 1
97816 Lohr am Main, Germany
Phone +49 (0) 93 52/40 30 20
my.support@boschrexroth.de
www.boschrexroth.de

© All rights reserved to Bosch Rexroth AG, also regarding any disposal, exploitation, reproduction, editing, distribution, as well as in the event of applications for industrial property rights.
The data specified above only serve to describe the product. No statements concerning a certain condition or suitability for a certain application can be derived from our information. The information given does not release the user from the obligation of own judgment and verification.
Please note that our products are subject to a natural process of wear and aging.

Notes

Bosch Rexroth AG
Industrial Hydraulics
Zum Eisengießer 1
97816 Lohr am Main, Germany
Phone +49 (0) 93 52/40 30 20
my.support@boschrexroth.de
www.boschrexroth.de

© All rights reserved to Bosch Rexroth AG, also regarding any disposal, exploitation, reproduction, editing, distribution, as well as in the event of applications for industrial property rights.
The data specified above only serve to describe the product. No statements concerning a certain condition or suitability for a certain application can be derived from our information. The information given does not release the user from the obligation of own judgment and verification.
Please note that our products are subject to a natural process of wear and aging.