

Modular standard power units

Type ABSKG

RE 51013

Edition: 2016-12

Replaces: 11.14



- ▶ Tank size 20, 40 and 60 liters

Contents

Features	1
Ordering code	2
Power unit set-up	3
The ABSKG configurator at www.boschrexroth.com/ics/abskg	4
Selection table:	
▶ Basic power unit	5 ... 7
▶ Control variants	8
Technical data	9
Characteristic curves	10
Circuit diagrams	11 ... 13
Example of an electric accumulator charging circuit	14
Dimensions	15 ... 23
Options:	
▶ Level switch N	24
▶ Oil pan O	25
▶ Hand pump P	26 ... 28
▶ Thermostat T	29
Accessories:	
▶ Maintenance indicator	29
▶ Filter replacement element for return flow filter	30
▶ Mating connectors	30
▶ Foot AB 40-09 for tank 40 = l; 60 l	30
▶ Return pipe PN16 for drain lines	31
Installation, commissioning, maintenance and operating instructions	32

Features

- ▶ Stable aluminum tank
- ▶ Modular design
- ▶ Compact power unit design
- ▶ Individual adjustment possible
- ▶ Versatile possible applications
- ▶ Additional options possible
- ▶ Clear, maintenance-friendly set-up

Information on available spare parts:
www.boschrexroth.com/spc

Ordering code

01	02	03	04	05	06	07	08	09	10	11	12	13	14
ABSKG	-	AL	9	/		/		/				/	

Power unit

01	Type ABSKG	ABSKG
----	------------	--------------

Tank size

02	20 liters	20
	40 liters	40
	60 liters	60

Tank material

03	Aluminum	AL
----	----------	-----------

AB standard tank

04	AB 40-09	9
----	----------	----------

Kind of set-up: Pump-motor group

05	Pump power unit vertically installed	V
----	--------------------------------------	----------

Pump type / size (see selection table page 5 to 7)

06	Gear pump, externally geared, < 4 cm ³	AZPB...
	Gear pump, externally geared, ≥ 4 cm ³ according to data sheet 10089	AZPF...
	Gear pump, internally geared according to data sheet 10213	GF2...
	Radial piston pump according to data sheet 11263	R4...

Motor frame size

07	(See selection table page 5 to 7)	
----	-----------------------------------	--

Basic power unit type

08	Without air heat exchanger	no code
	With air heat exchanger	L

Control variant (see page 8)

09	Pressure control unit type ABZRD-01/10 to DCCS11010	1
	Subplate AB 42-09GG...DMAB	6
	Subplate AB 42-09GG...DMAB with accumulator charging circuit	7

Number of controls

10	With control variant 6 and 7 (with control variant 7, one control is required for the accumulator charging valve)	1 ... 6; 8
----	---	-------------------

Options

11	Level switch	N
	Oil pan	O
12	Hand pump	P
	Thermostat	T

Circuit diagram short symbols (determination after receipt of the order, example)

13	Responsible department e.g. 013	
14	Serial number e.g. A487	

Order example:

ABSKG-40AL9/VGF2-011/100L/63NT/013A487

Power unit set-up

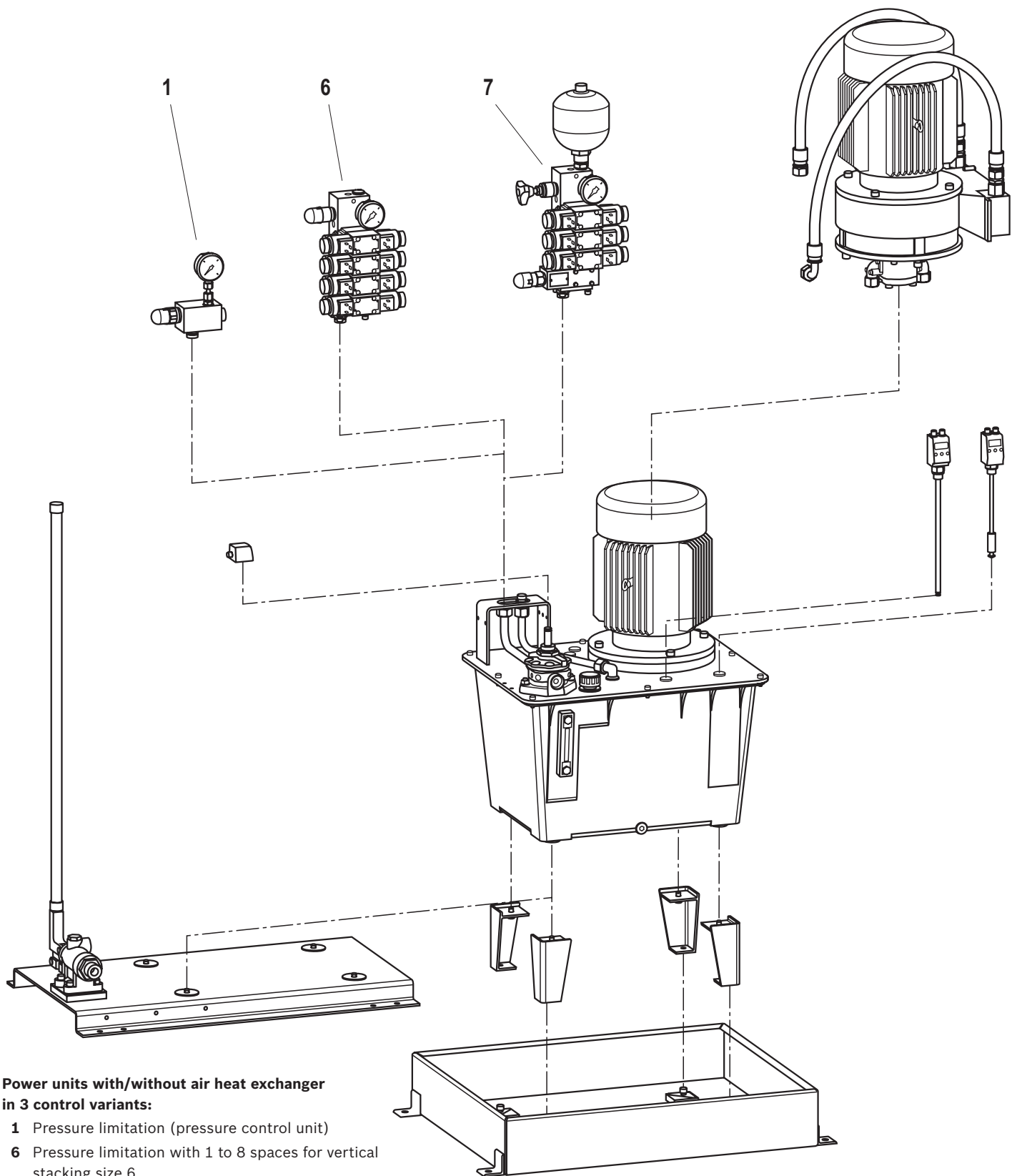

Power units with/without air heat exchanger in 3 control variants:

- 1 Pressure limitation (pressure control unit)
- 6 Pressure limitation with 1 to 8 spaces for vertical stacking size 6
- 7 Pressure limitation with 1 to 8 spaces for vertical stacking size 6 including accumulator charging circuit

The ABSKG configurator at www.boschrexroth.com/ics/absgk

The configurator for the modular ABSKG standard power units helps you configure your individual power unit incl. manifold and/or pressure control unit in a simple and convenient way.

This is done online by selecting the relevant product components and application conditions (e.g. pump type incl. size, relevant operating pressure).

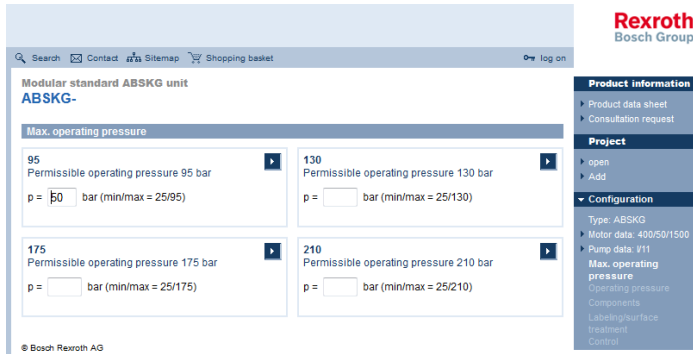

Thanks to the intuitive menu navigation, you are guided safely through the required configuration steps. Related features are clearly arranged on one page.

Apart from configuring the generator set, you can also choose from an extensive selection of control options (e.g. with pressure control unit or vertical stacking).



Configuration documentation Modular standard ABSKG unit



Model code	ABSKG-40AL9/VAZPF-005/112M/66N	
Description		
Basic unit		
Type	ABSKG	Modular standard unit ABSKG type
Motor voltage	400	400 V
Motor frequency	50	50 Hz
Nominal speed	1500	1500 rpm
Pump design	A	External geared pump
Nominal size	5	Displacement 5 cm ³
Pumped flow	7.1	l/min
Max. operating pressure	250	Permissible operating pressure 250 bar
Operating pressure	245	Operating pressure 245 bar
Maximum set pressure of pressure relief valve	315	Maximum set pressure of pressure relief valve 315 bar
Drive power	4.00	4.00 kW
Container size	40	40 liters
Oil-air cooler		Without

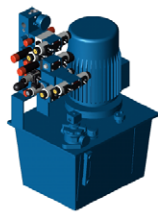

When the configuration is finished, you can have the complete configuration documentation sent to you via email including material list, circuit diagram, 2D drawing and 3D model (STEP). This is done by way of an automatic request to your local distributor who will promptly contact you and send you an offer.

Selection table basic power unit with tank size 20 (type ABSKG-20) kind of set-up V

Set-up pump power units with electric motors efficiency class IE2 or IE3 (according to IEC 60034-30)
at 50 Hz (HLP 46; 50 °C; 32 mm²/s)

Pump	$q_{V \max}$ at 1450 min ⁻¹ in l/min	p_{\max} in bar	Power P at 50 Hz in kW	Electric motor frame size	Material no. without heat exchanger	Weight in kg	Material no. with heat exchanger	Weight in kg
AZPB 2.0	2.9	60	0.37	71	R901440637	25	–	–
		130	0.75	80	R901434131	33	–	–
		250/270 (intermittent)	1.5	90L	R901434137	40	R901434139	48
AZPB 3.1	4.5	40	0.37	71	R901440738	25	–	–
		80	0.75	80	R901434146	33	–	–
		170	1.5	90L	R901434147	40	R901434148	48
		250	2.2	100L	R901434150	45	R901434153	57
AZPF-004	5.8	25	0.37	71	R901440743	27	–	–
		65	0.75	80	R901434172	33	–	–
		130	1.5	90L	R901434175	39	R901434176	50
		250/265 (intermittent)	3	100L	R901434532	53	R901434533	62
AZPF-005	7.9	45	0.75	80	R901434536	33	–	–
		95	1.5	90	R901434540	40	R901434542	50
		195	3	100L	R901434547	53	R901434548	62
		250/270 (intermittent)	4	112M	R901434549	60	R901434641	69
AZPF-008	11.6	60	1.5	90L	R901434643	40	R901434671	50
		130	3	100L	R901434672	53	R901434673	62
		175	4	112M	R901434684	60	R901434691	69
R4-1,6-700	2.1	315	1.5	90L	R901434699	48	R901434700	55
R4-3,15-500	5.1	290	3	100L	R901434702	63	R901434703	67

Selection table basic power unit with tank size 40 (type ABSKG-40) kind of set-up V

Set-up pump power units with electric motors efficiency class IE2 or IE3 (according to IEC 60034-30)
at 50 Hz (HLP 46; 50 °C; 32 mm²/s)

Pump	$q_{V \max}$ at 1450 min ⁻¹ in l/min	p_{\max} in bar	Power P at 50 Hz in kW	Electric motor frame size	Material no. without heat exchanger	Weight in kg	Material no. with heat exchanger	Weight in kg
AZPB 2.0	2.9	60	0.37	71	R901462033	30	–	–
		130	0.75	80	R901433981	39	–	–
		250/270 (intermittent)	1.5	90L	R901433996	46	R901433999	53
AZPB 3.1	4.5	170	1.5	90L	R901434001	46	R901434003	53
		250	2.2	100L	R901434007	51	R901434008	62
AZPF-004	5.8	130	1.5	90L	R901434044	45	R901434056	55
		250/265 (intermittent)	3	100L	R920046270	59	R901434058	67
AZPF-005	7.9	95	1.5	90	R901434064	45	R901434070	55
		190	3	100L	R901434073	59	R901434077	67
		250/270 (intermittent)	4	112M	R901434086	66	R901434087	74
AZPF-008	11.6	60	1.5	90L	R901434090	45	R901434091	55
		130	3	100L	R901434092	59	R901434093	67
		175	4	112M	R901462000	66	R901462027	74
		245	5.5	132S	R901434095	81	R901434098	92
GF2-011	16	90	3	100L	R901434099	60	R901434100	69
		130	4	112M	R901434111	67	R901434113	76
		180	5.5	132S	R901434114	85	R901434116	93
		210/240 (intermittent)	7.5	132M	R901407200	96	R901407201	104
R4-1,6-700	2.1	315	1.5	90L	R901434117	51	R901434118	61
R4-3,15-500	5.1	290	3	100L	R901434120	62	R901434121	73
R4-6,3-500	8.4	315	5.5	132S	R901434122	89	R901434125	98
R4-8,0-500	11.5	315	7.5	132M	R901407203	102	R901407204	111

Selection table basic power unit with tank size 60 (type ABSKG-60) kind of set-up V

Set-up pump power units with electric motors efficiency class IE2 or IE3 (according to IEC 60034-30) at 50 Hz (HLP 46; 50 °C; 32 mm²/s)

Pump	$q_{V \max}$ at 1450 min ⁻¹ in l/min	p_{\max} in bar	Power <i>P</i> at 50 Hz in kW	Electric motor frame size	Material no. without heat exchanger	Weight in kg	Material no. with heat exchanger	Weight in kg
AZPF-004	5.8	130	1.5	90L	R901433565	59	R901433566	69
		250/265 (intermittent)	3	100L	R901433570	72	R901433575	81
AZPF-005	7.9	95	1.5	90	R901433576	59	R901433577	69
		190	3	100L	R901433579	73	R901433595	81
		250/270 (intermittent)	4	112M	R901433648	79	R901433649	88
AZPF-008	11.6	60	1.5	90L	R901433650	59	R901433651	69
		130	3	100L	R901433653	73	R901433654	81
		175	4	112M	R901461991	80	R901461994	88
		245	5.5	132S	R901433655	92	R901433656	104
GF2-011	16	90	3	100L	R901433658	74	R901433664	83
		130	4	112M	R901433667	81	R901433674	89
		180	5.5	132S	R901433964	96	R901433965	105
		210/240 (intermittent)	7.5	132M	R901407150	107	R901407163	116
GF2-016	23.2	85	4	112M	R901433968	81	R901433970	90
		120	5.5	132S	R901433971	97	R901433973	105
		165	7.5	132M	R901406078	108	R901407165	116
R4-3,15-500	5.1	290	3	100L	R901433974	76	R901433975	86
R4-6,3-500	8.4	315	5.5	132S	R901433976	101	R901433978	109
R4-8,0-500	11.5	315	7.5	132M	R901407168	114	R901407170	122

With higher noise requirements, we recommend using the following hydraulic pumps (upon request):

Pump size	$q_{V \max}$ at 1450 min ⁻¹ in l/min	Material no.	Type	Comment
004	5.8	R918C03744	AZPS-11-004RCB20MB	Identical drive shaft, front cover, line connections as the pumps of type AZPF used in the basic power units
005	7.9	R918C03756	AZPS-11-005RCB20MB	
008	11.6	R918C03771	AZPS-11-008RCB20MB	
012	17.4	R918C03842	AZPJ-22-012RCB20MB	
016	23.2	R918C03846	AZPJ-22-016RCB20MB	

Project planning information for the use of air heat exchangers:

- ▶ In power units with air heat exchanger, smoothly switching valves according to data sheet 23183 are to be preferably used in order to reduce pressure peaks in the tank line.
- ▶ Due to the abrupt opening of releasable check valves, application-inherent pressure peaks in the tank line may also occur if smoothly switching valves are used.
- ▶ For unloading large decompression volumes, a free return flow port is available leading directly into the tank.
- ▶ Due to the use of the air heat exchanger in the return line, the flow from the system/of the application is to be observed. (E.g. increase in the flow due to the use of differential cylinders and/or accumulator applications.) For more detailed information on the back pressure to be expected see page 10.

Selection table control variant 1

Pressure control unit type ABZRD-01/10 to DCCS11010

Pressure rating in bar	50	100	200	315
Material no.	R900827584	R900827585	R900827581	R900827580
Weight in kg	3.0			

Selection table control variant 6

Subplate type AB42-09/06..DMAB with measuring port consisting of:

- ▶ Plate AB42-09/06..DMAB
- ▶ Pressure gauge size 63 according to data sheet 50205
- ▶ Pressure relief valve DBDS 6 K1X/... according to data sheet 25402

Number of controls	Pressure rating in bar				Weight in kg
	50	100	200	315	
1	R900868291	R900867747	R900867748	R900867749	5.0
2	R900868317	R900868009	R900868017	R900868024	6.5
3	R900868318	R900868010	R900868018	R900868025	8.0
4	R900868319	R900868011	R900868019	R900868026	9.5
5	R900868320	R900868013	R900868020	R900868027	11.0
6	R900868321	R900868014	R900868021	R900868028	12.5
8	R900868323	R900868016	R900868023	R900868030	15.5

Selection table control variant 7

Subplate type AB42-09/06..DMAB with accumulator charging circuit and measuring port consisting of:

- ▶ Plate AB42-09/06..DMAB
- ▶ Pressure gauge size 63; data sheet 50205
- ▶ Pressure relief valve DBDH 6 K1X/...E according to data sheet 25402
- ▶ Pressure cut-off valve DA 6 VA2A5X/...FSM according to data sheet 26405
- ▶ Diaphragm type accumulator 0.7 l HAD0,7-350-2X/2G04E-1N111-BA according to data sheet 50150

Number of controls	Pressure rating pressure relief valve/pressure cut-off valve in bar			Weight in kg
	110 / 100	210 / 200	315 / 315	
1	R901250197	R901250189	R901250182	12.3
2	R901250196	R901250188	R901250181	13.8
3	R901250195	R901250187	R901250180	15.3
4	R901250194	R901250186	R901250179	16.8
5	R901250193	R901250185	R901250178	18.3
6	R901250191	R901250184	R901250177	19.8
8	R901250190	R901250183	R901250176	22.8

Valve settings from pressure valves:

At the factory, the valves are - upon delivery - set to the pressures indicated in the hydraulic circuit diagram.

Project planning information:

Diaphragm type accumulators (type of mounting (oil port form) E or E5) according to data sheet 50150 can be directly mounted onto plate AB42-09 up to a volume of 2.0 liters.

Technical data

(For applications outside these parameters, please consult us!)

Tank capacity	20; 40; 60		
Line connections	Connection thread according to ISO 1179 (DIN 3852-2 form X) and/or pipe connections according to ISO 8434 part 1		
Hydraulic fluid	Mineral oil HLP according to DIN 51524; part 2 e.g. with operating temperature 50 °C ISO VG46 DIN 3448 (other hydraulic fluids upon request!) ▶ Please observe our provisions according to data sheet 90220 ▶ Different oil types must not be mixed ▶ According to the operating conditions, the hydraulic fluid must be renewed at certain intervals.		
Return flow filter with filter element according to DIN 24550 according to data sheet 51424	▶ Tank 20 l	10TEN0040-H10XLA00-V2,2-M-R3...	
	▶ Tank 40 l, 60 l	10TEN0063-H10XLA00-V2,2-M-R3...	
Filter rating	▶ Breathing filter	µm	10
	▶ Return flow filter	µm	10
Viscosity range with pump type	▶ AZPB; AZPF	mm ² /s	12 ... 800 (recommended range 20 ... 100)
	▶ GF2	mm ² /s	10 ... 300
	▶ R4	mm ² /s	10 ... 200
Required cleanliness classes according to ISO 4406 for basic power units with pump type ¹⁾	20/18/15		
Electric motor	▶ Motor type	Three-phase asynchronous motor	
	▶ Efficiency class	0,37 kW IE2; 0,75 up to 7,5 kW IE3	
	▶ Voltage according to IEC 38 U	V	Up to 3 kW 230/400 V 50 Hz; from 4 kW 400/690 V 50 Hz
	▶ Number of pole pairs	4	
	▶ Speed	min ⁻¹	1450
	▶ Protection class	IP55	
Heat exchanger	▶ Type	Oil-air	
	▶ Operating pressure max.	bar	16
Type of piping	Tube forming system for fittings with 24° cone connection or double-edge cutting ring according to ISO 8434 part 1 (DIN 2353) easy/heavy series according to the technical possibilities		
Surface treatment:	▶ Steel components; pipes	Cr(VI)-free metal surface coatings	
	▶ Oil pan steel design	Single-layer coating RAL 5010	
	▶ Tank aluminum cast	Without additional surface treatment	
	▶ Connection manifold	Phosphate coating according to EN12476	
	▶ Components	Remain in the state as delivered by the manufacturer. This offers at least temporary corrosion protection.	

¹⁾ The required cleanliness classes of the other components must be adhered to in hydraulic systems. Effective filtration

prevents faults and at the same time increases the life cycle of the components.

Heat power losses

Tank	Surface with cover in m ²	Heat power loss P30 in kW	Specific heat power loss in kW/°C
20	0.5	0.17	0.0055
40	1.0	0.78	0.026
60	1.3	0.87	0.029

Characteristic curves (average) for air heat exchanger

Flow resistance cooling element

Pressure differential Δp dependent on the flow q_v with an oil viscosity of 32 mm²/s.

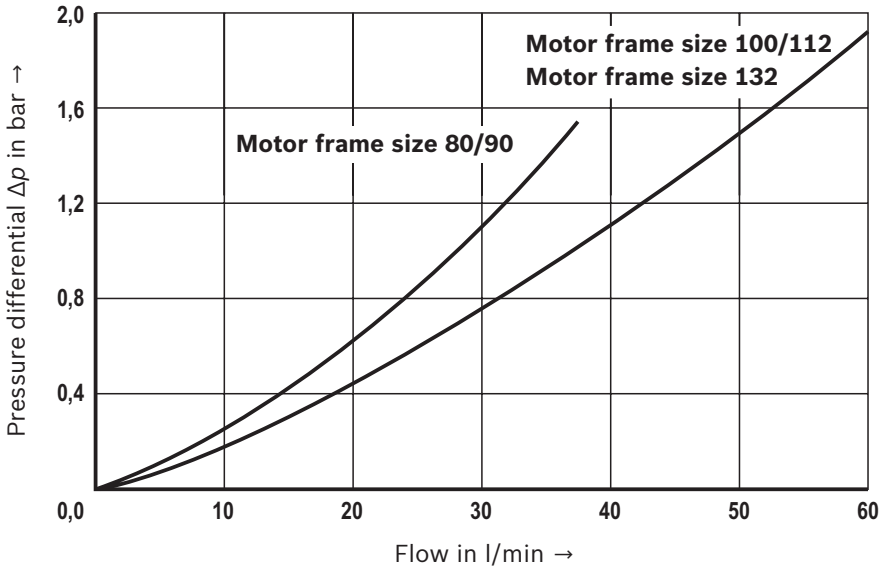

Correction factor k for Δp values dependent on other viscosities

Kinematic viscosity in mm ² /s	15	22	32	46	68	100	150	220	460
k	0.64	0.73	1	1.28	1.62	2.65	3.9	6.9	17.1

Specific cooling power

of the air heat exchanger dependent on the flow q_v and the temperature difference $\Delta t = 1$ K (oil inlet to air inlet) at fan wheel speed 1500 min⁻¹.

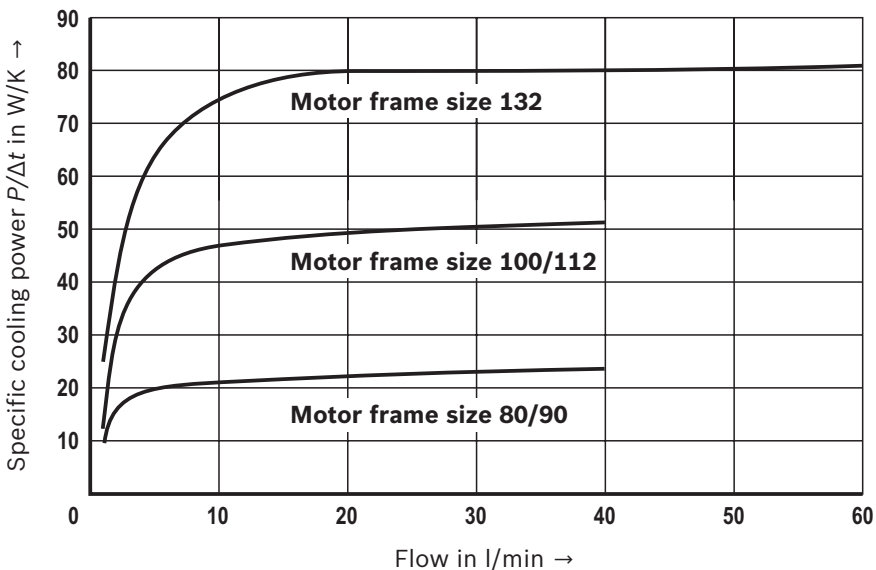

Circuit diagrams: Control variant 1

Control variant 1 without air heat exchanger

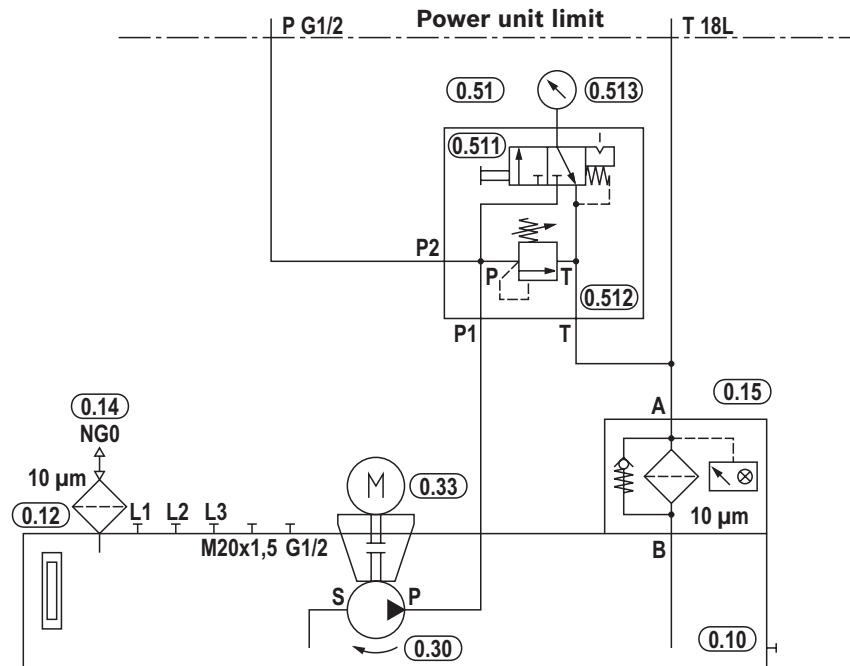

Control variant 1 with air heat exchanger

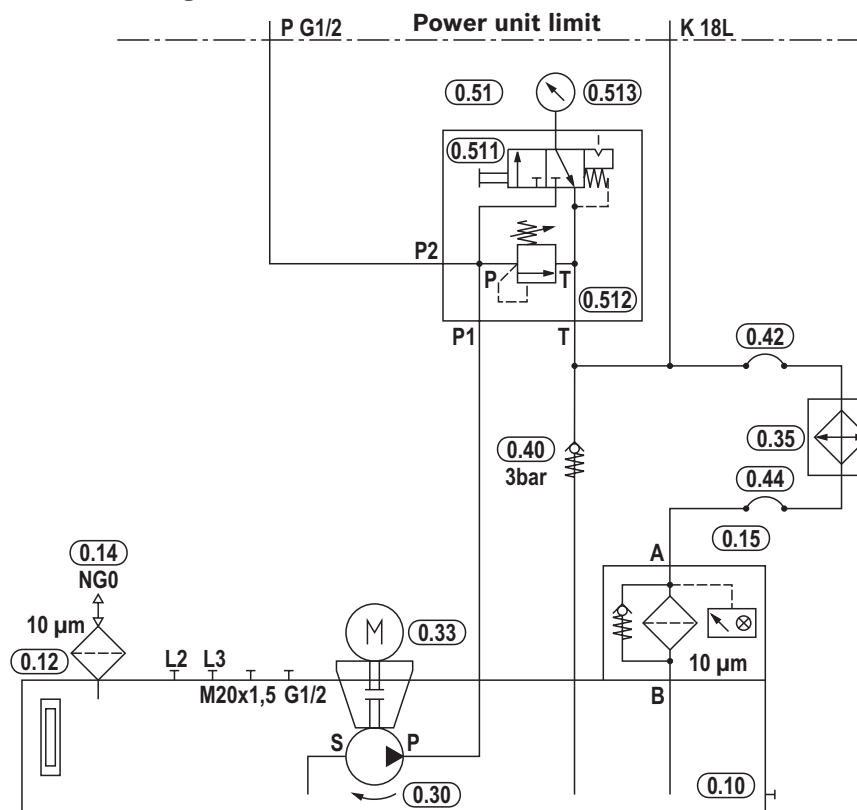

Notice!

No port L3 with 40 l power unit with motor of frame size 132
 No port G1/2 on tank with 20 l power unit

Circuit diagrams: Control variant 6

Control variant 6 without air heat exchanger

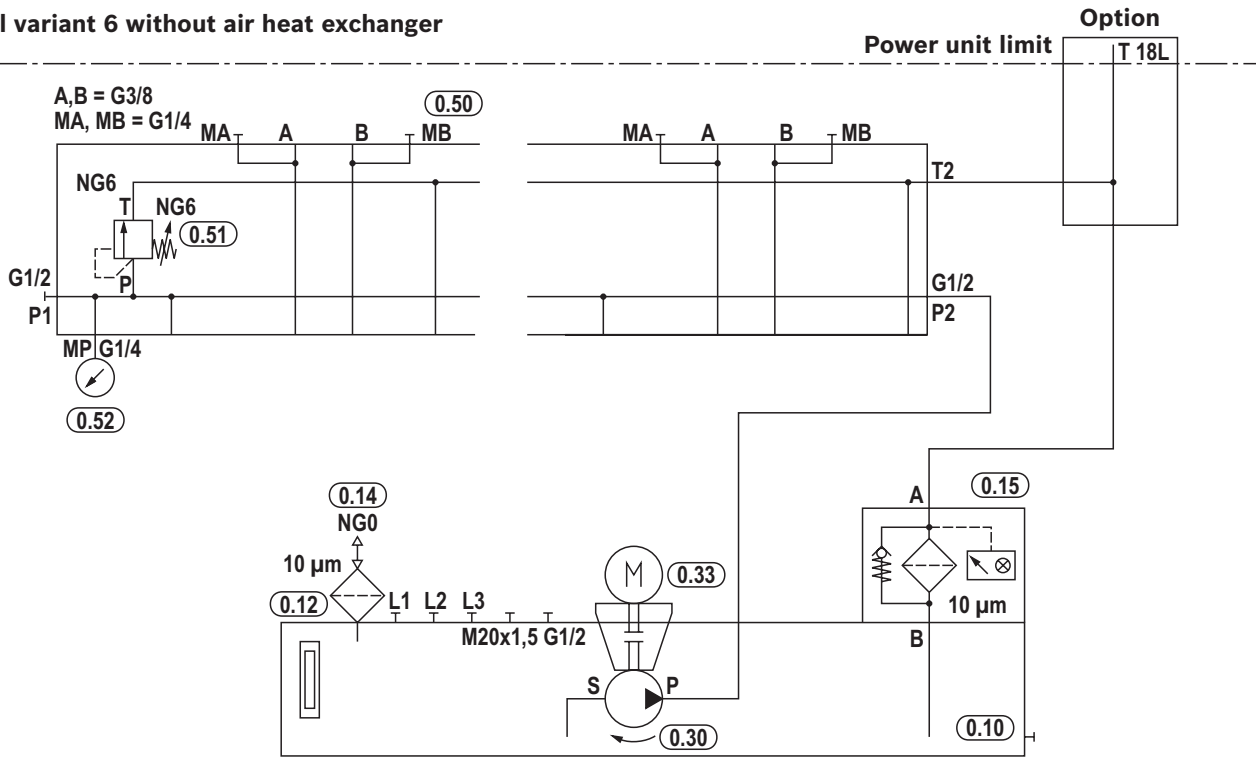

Control variant 6 with air heat exchanger

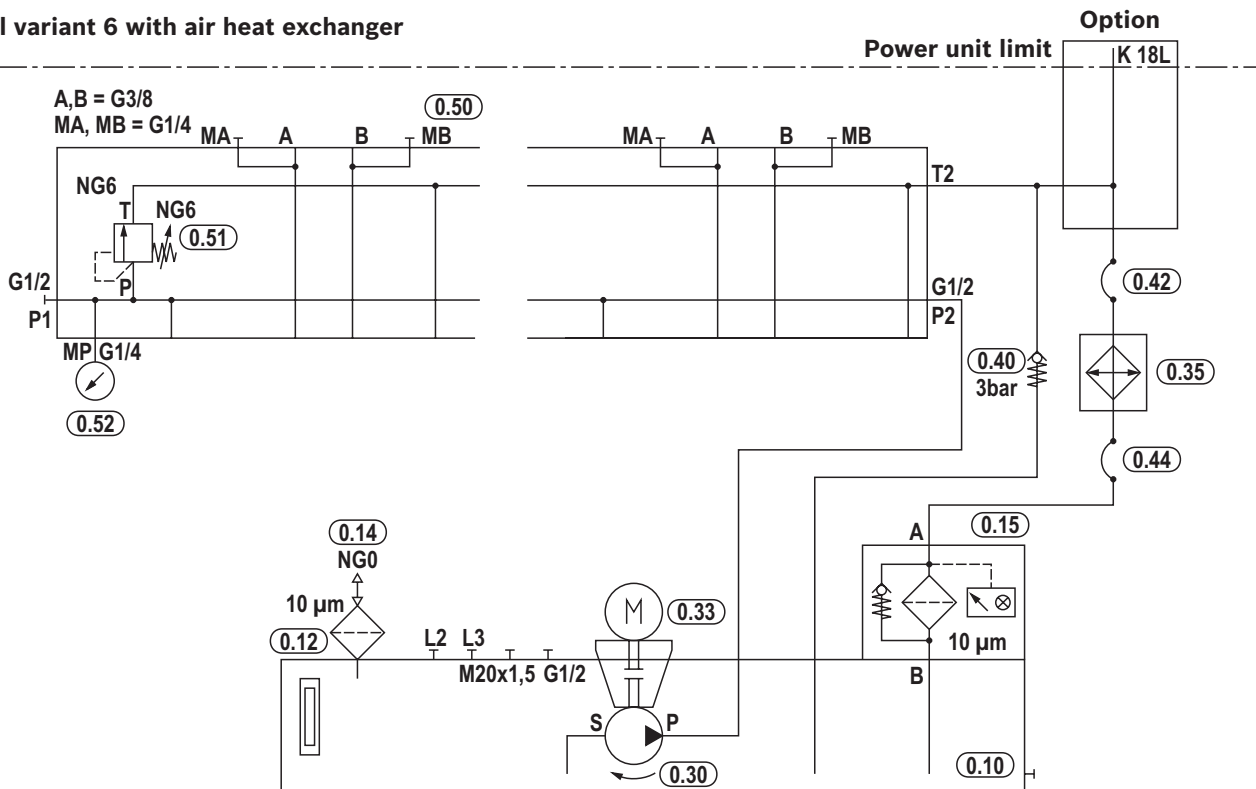

Notice!

- No port L3 with 40 l power unit with motor of frame size 132
- No port G1/2 on tank with 20 l power unit

Circuit diagrams: Control variant 7

Control variant 7 without air heat exchanger

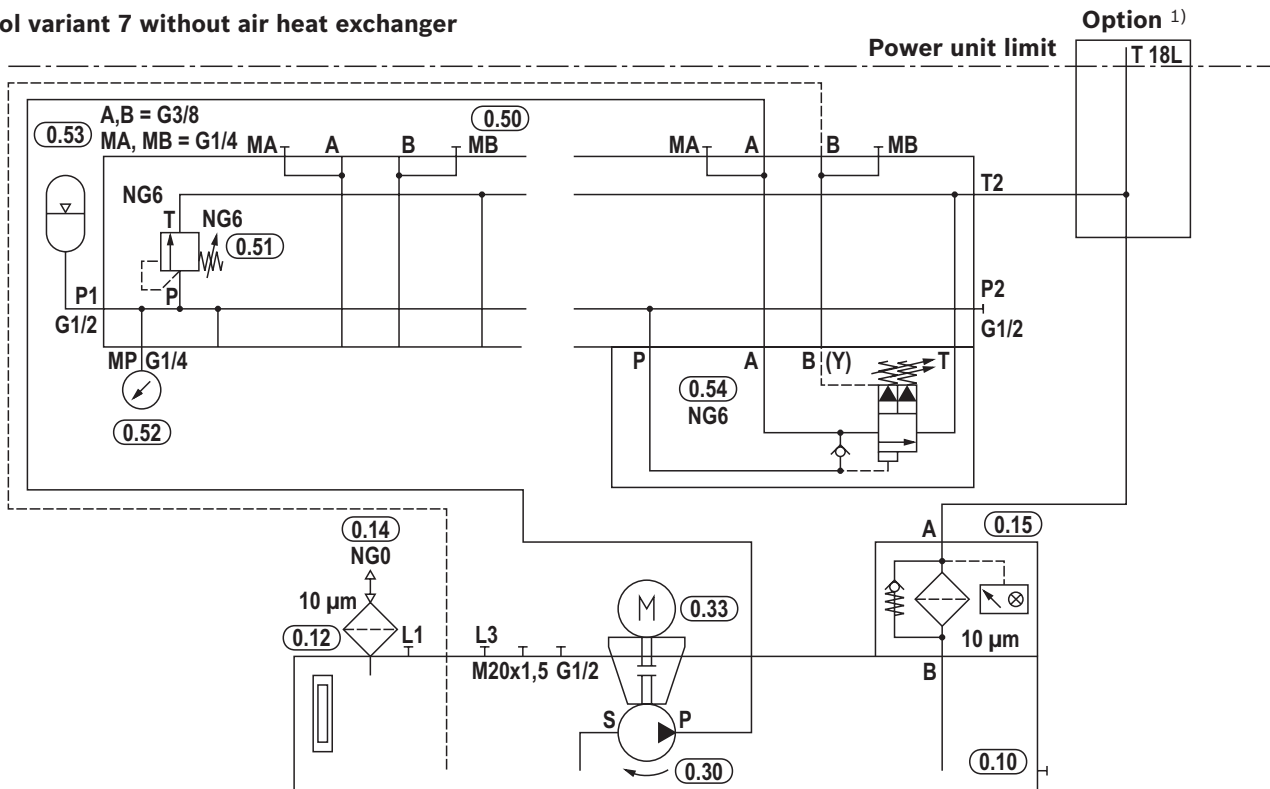

Control variant 7 with air heat exchanger

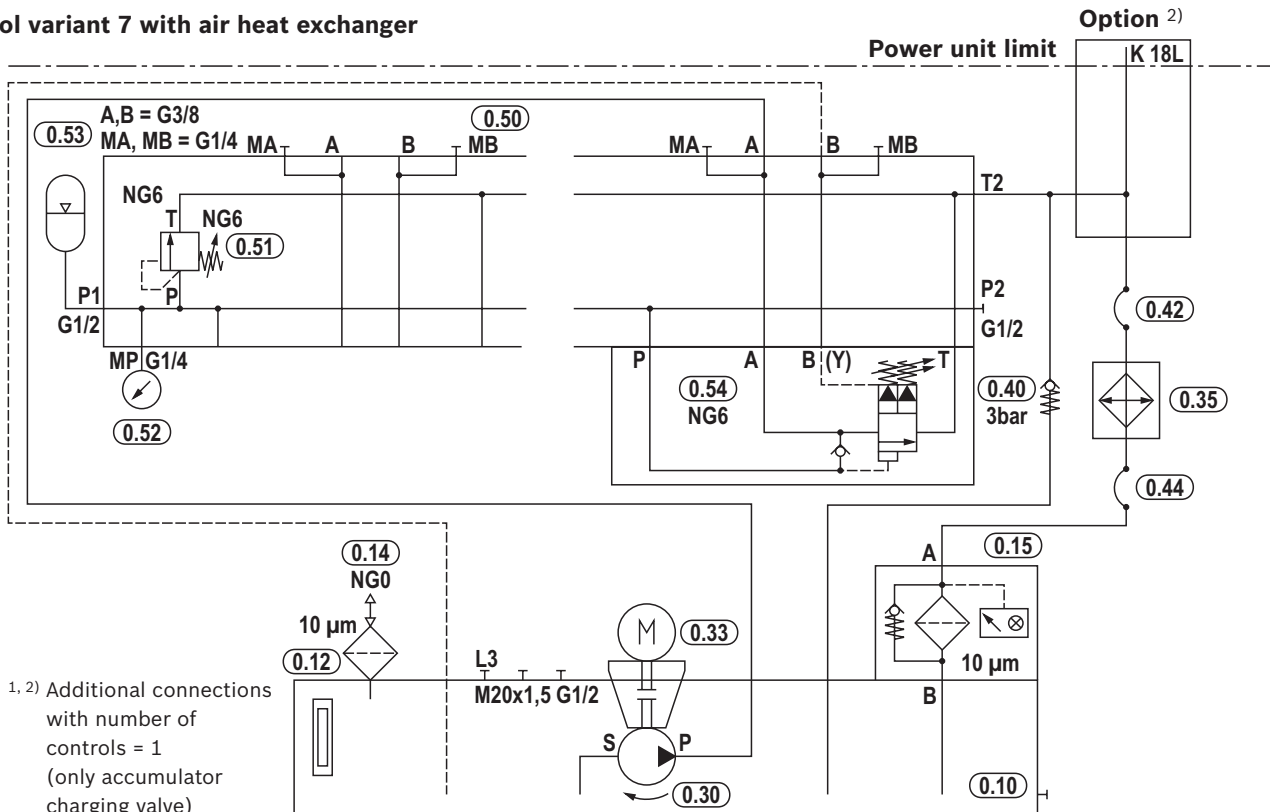

1, 2) Additional connections with number of controls = 1 (only accumulator charging valve)

Notice!

No port L3 with 40 l power unit with motor of frame size 132
 No port G1/2 on tank with 20 l power unit

Example of an electric accumulator charging circuit:

Circuit diagram

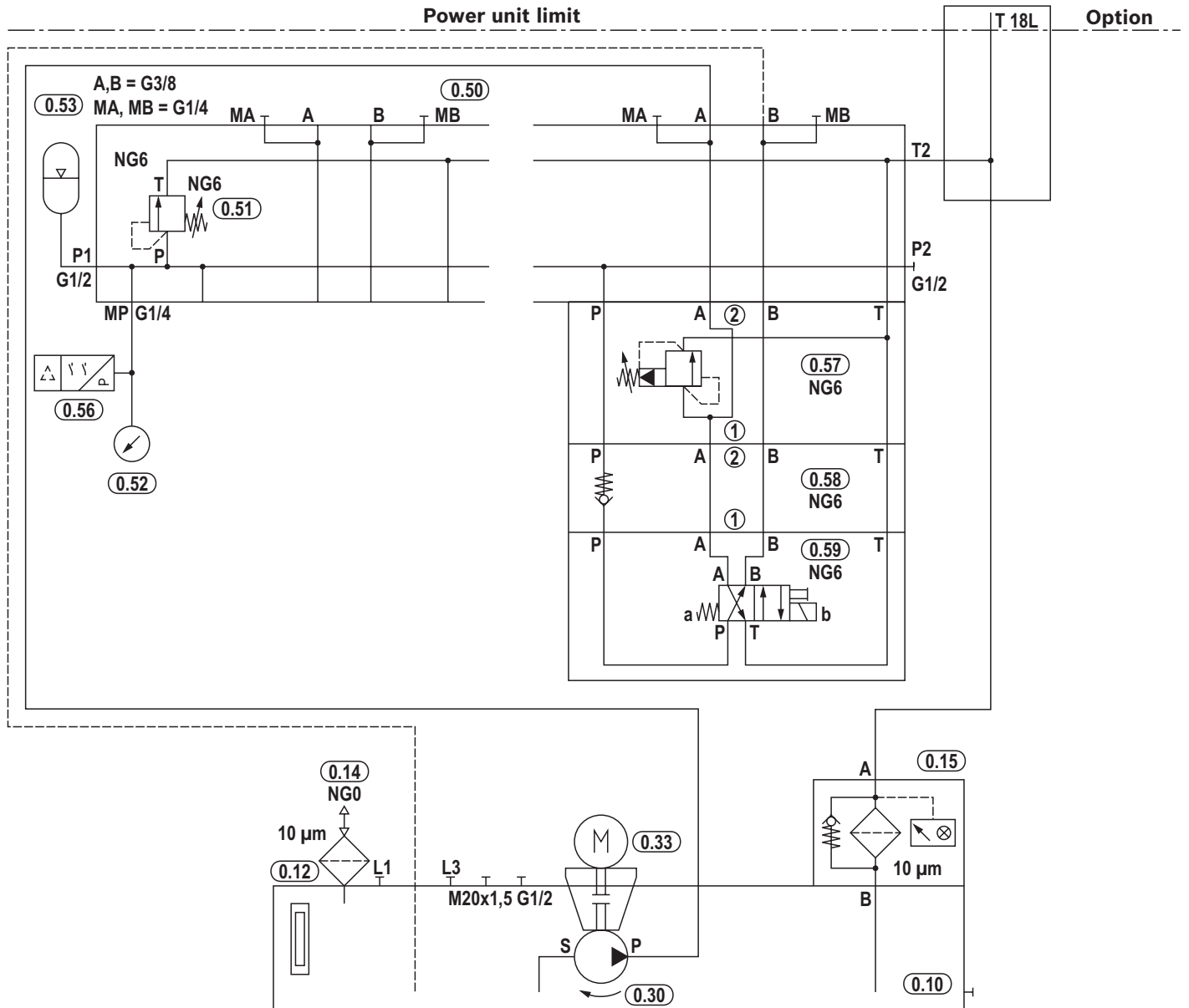

Item	Type	Data sheet
0.56	HEDE 10.../2/	30278
0.57	ZDB6_VA_-4X/_V	25751
0.58	R901086591 Z1S 6 P05-4X/V SO104	21534
0.59	R900572186 4WE 6 Y73-6X/EG24N9K4/A12	23183

Attention:

Observe the limitations of use of the valves (e.g. switching power limits of the solenoids).

Dimensions: Type ABSKG-20, control variant 1 (dimensions in mm)

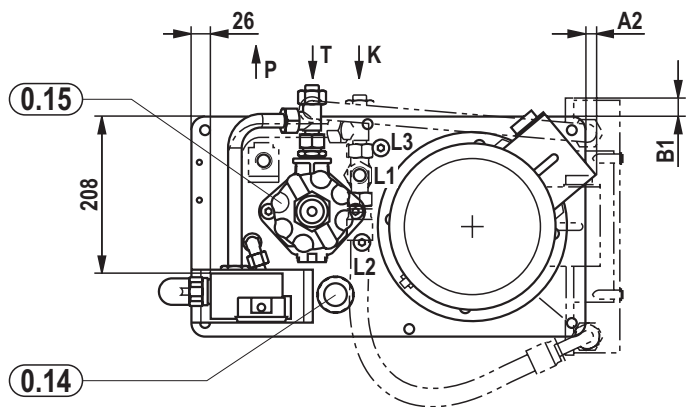
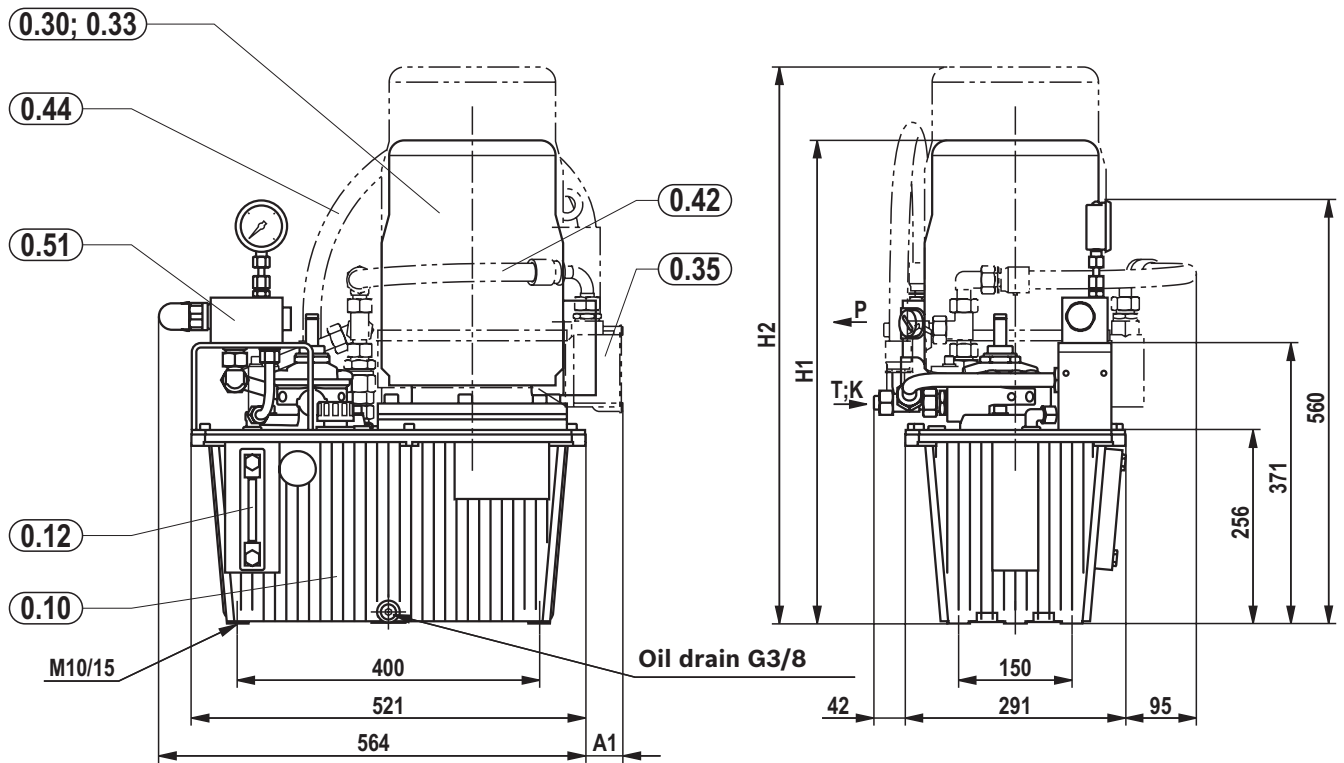

- 0.10** Tank
- 0.12** Oil level display
- 0.14** Filling
- 0.15** Return flow filter
- 0.30** Pump
- 0.33** Electric motor
Pump carrier
Coupling
- 0.35** Air heat exchanger
(basic power unit .../L)
- 0.42** Hose to the
heat exchanger
- 0.44** Hose from the heat
exchanger to the filter
- 0.51** Pressure control unit

Line connections without air heat exchanger		Line connections with air heat exchanger	
P	G1/2	P	G1/2
T	18L	K	18L
L2; L3	G3/8	L2; L3	G3/8
L1	G1/2	-	-

Motor frame size		71	80/90	100/112
Without air heat exchanger	A2	-	-	-/15
	H1	490	532/579 ¹⁾	623 ²⁾ /647
With air heat exchanger	A1	-	-/32	51
	B1	-	-	29
	H2	-	-/660	720/744

¹⁾ +25 mm with pump R4

²⁾ +45 mm with pump R4

Dimensions: Type ABSKG-40, control variant 1 (dimensions in mm)

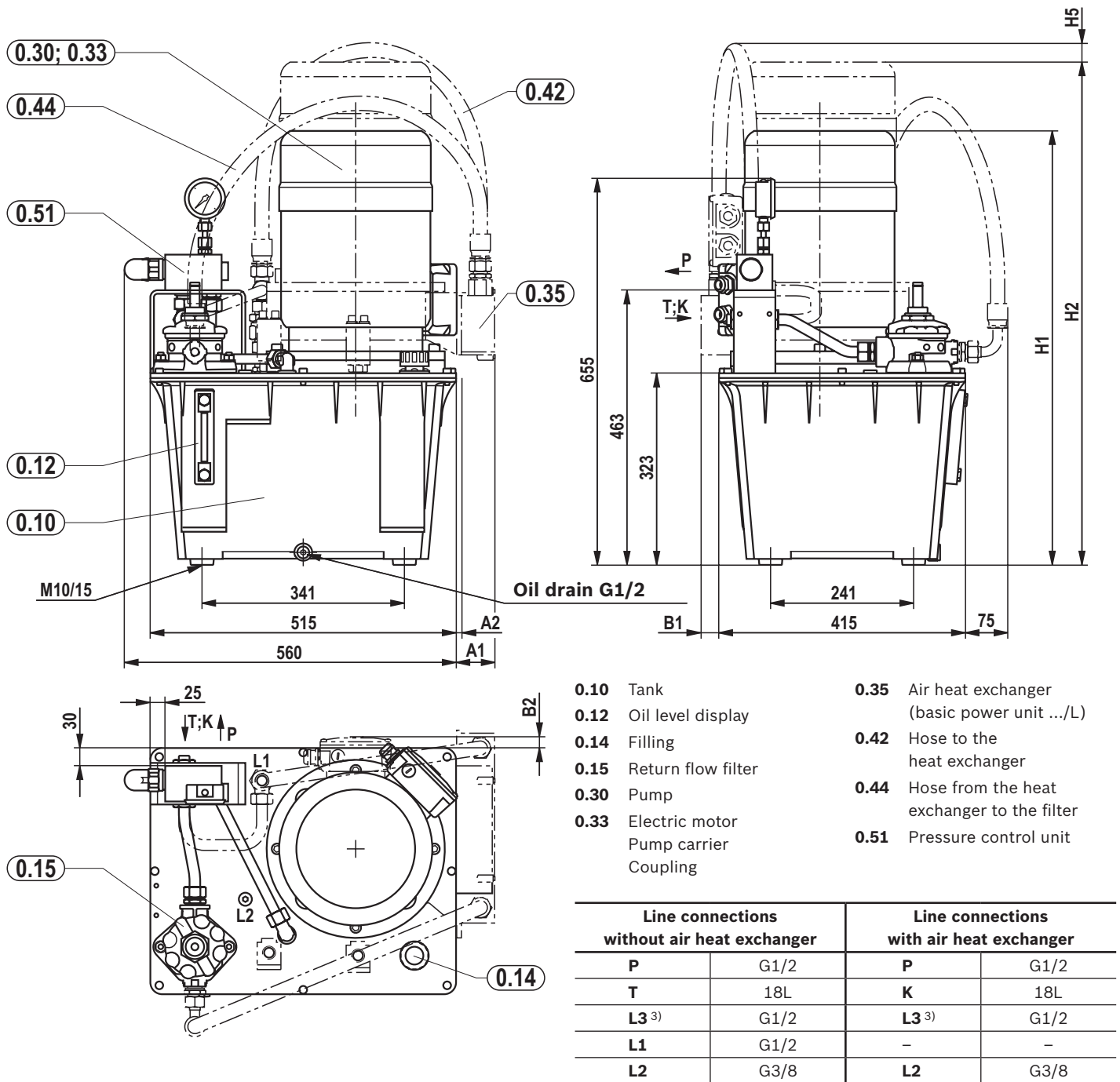

Motor frame size		71	80/90	100/112	132S/132M
Without air heat exchanger	A2	-	-	-/10	-
	B2	-	-	-	20
	H1	557	599/646	690/714	728/766
With air heat exchanger	A1	-	-/31	50	66
	B1	-	-	14	30
	H2	-	-/727	787/811	844/882
	H5	-	-/65	30/30	40/50

³⁾ No port L3 with power unit with motor of frame size 132

Dimensions: Type ABSKG-60, control variant 1 (dimensions in mm)

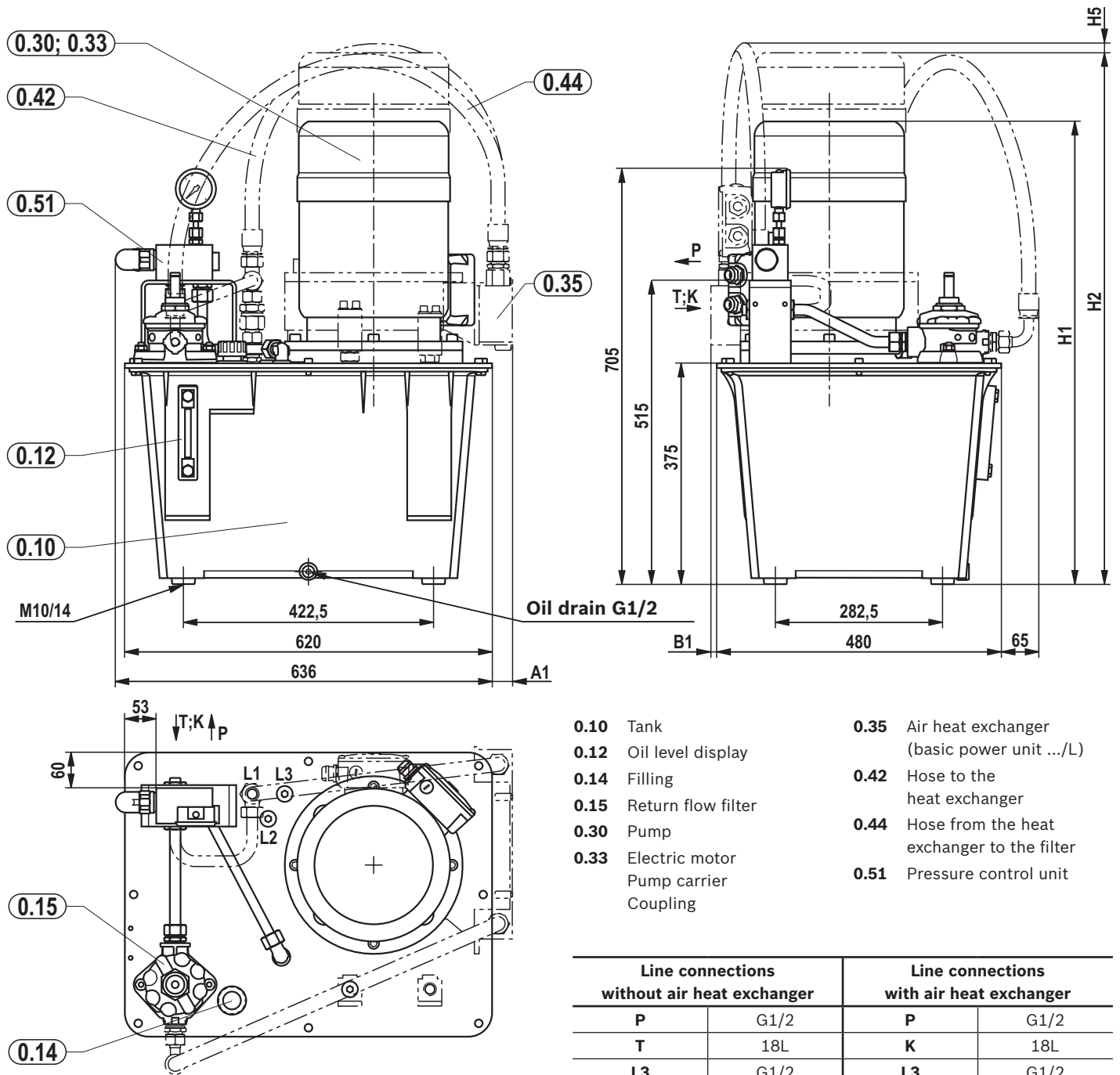

- 0.10** Tank
- 0.12** Oil level display
- 0.14** Filling
- 0.15** Return flow filter
- 0.30** Pump
- 0.33** Electric motor
Pump carrier
Coupling
- 0.35** Air heat exchanger
(basic power unit .../L)
- 0.42** Hose to the
heat exchanger
- 0.44** Hose from the heat
exchanger to the filter
- 0.51** Pressure control unit

Line connections without air heat exchanger		Line connections with air heat exchanger	
P	G1/2	P	G1/2
T	18L	K	18L
L3	G1/2	L3	G1/2
L1	G1/2	-	-
L2	G3/8	L2	G3/8

Motor frame size		71	80/90	100/112	132S/132M
Without air heat exchanger	H1	(607)	(649)/696	740/764	778/816
	A1	-	-	-	35
With air heat exchanger	B1	-	-	-	10
	H2	-	-/777	837/861	894/932
	H5	-	-/55	35/25	25/40

Dimensions: Type ABSKG-20, control variant 6 (dimensions in mm)

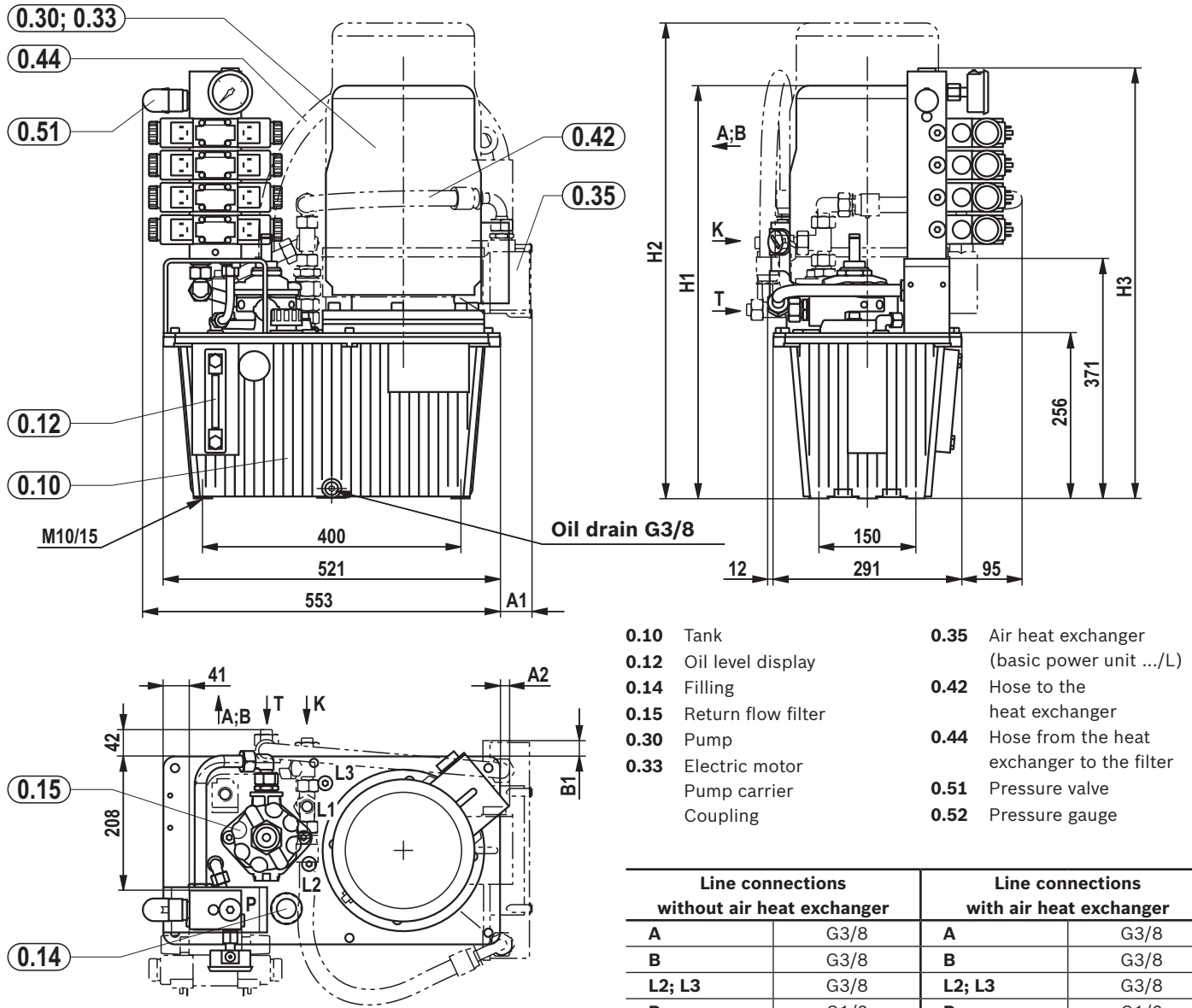

- 0.10** Tank
- 0.12** Oil level display
- 0.14** Filling
- 0.15** Return flow filter
- 0.30** Pump
- 0.33** Electric motor
Pump carrier
Coupling
- 0.35** Air heat exchanger
(basic power unit .../L)
- 0.42** Hose to the
heat exchanger
- 0.44** Hose from the heat
exchanger to the filter
- 0.51** Pressure valve
- 0.52** Pressure gauge

Line connections without air heat exchanger		Line connections with air heat exchanger	
A	G3/8	A	G3/8
B	G3/8	B	G3/8
L2; L3	G3/8	L2; L3	G3/8
P	G1/2	P	G1/2
T (optional)	18L	K (optional)	18L
L1	G1/2	-	-

Motor frame size		71	80/90	100/112
Without air heat exchanger	A2	-	-	-/15
	H1	490	532/579 ¹⁾	623 ²⁾ /647
With air heat exchanger	A1	-	-/32	51
	B1	-	-	29
	H2	-	-/660	720/744

¹⁾ +25 mm with pump R4

²⁾ +45 mm with pump R4

Dimensions: Dimension H3

Number of controls	1	2	3	4	5	6	8
H3	516	566	616	666	716	766	866

Attention: The maximum dimensions may differ due to the attached valves.

Dimensions: Type ABSKG-40, control variant 6 (dimensions in mm)

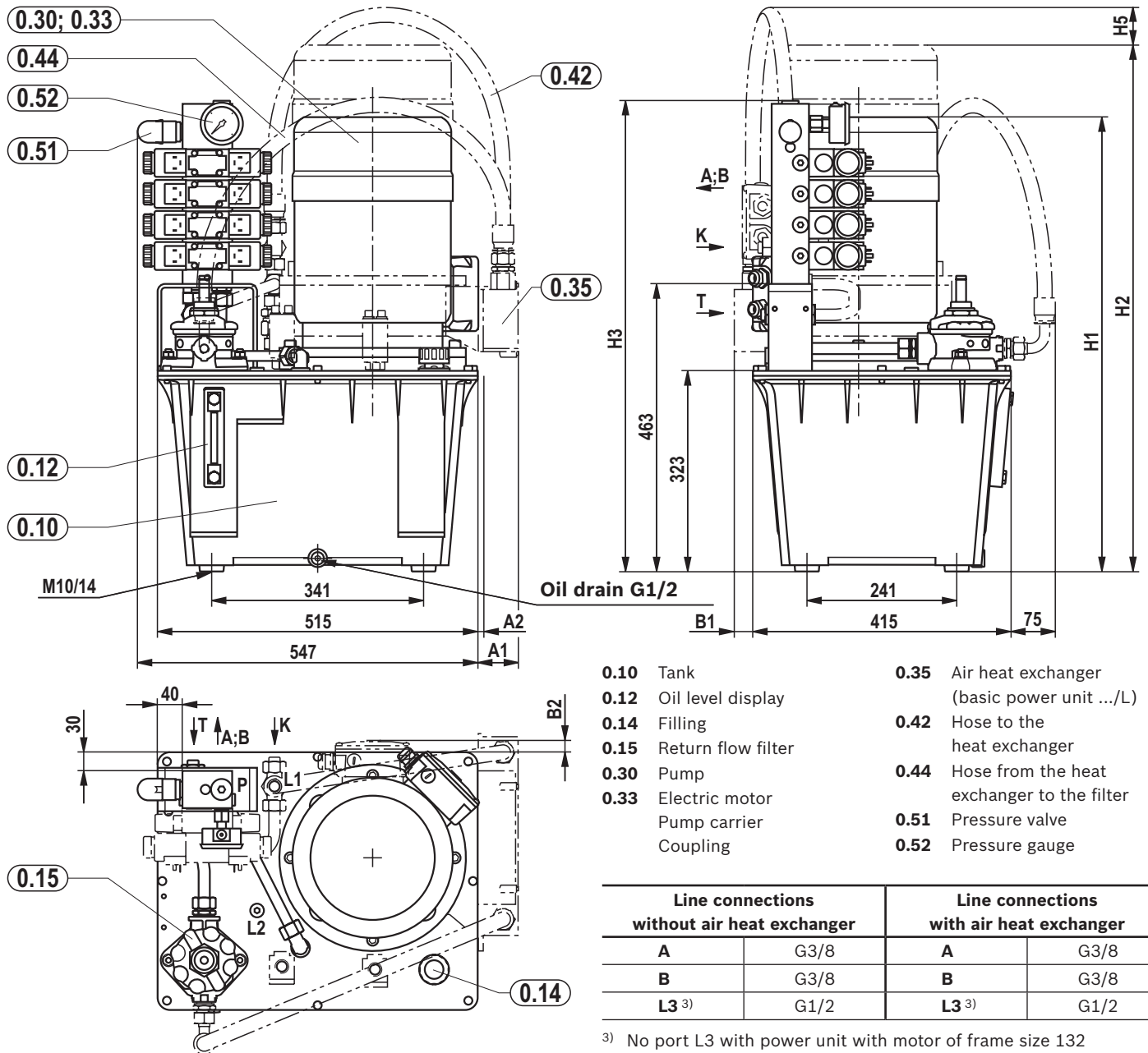

Motor frame size		71	80/90	100/112	132S/132M
Without air heat exchanger	H1	557	599/646	690/714	728/766
	A2	-	-	-/10	-
	B2	-	-	-	20
With air heat exchanger	A1	-	-/31	50	66
	B1	-	-	14	30
	H2	-	-/727	787/811	844/882
	H5	-	-/95	60/60	70/80

Dimensions: Dimension H3

Number of controls	1	2	3	4	5	6	8
H3	608	658	708	758	808	858	958

Attention: The maximum dimensions may differ due to the attached valves.

Dimensions: Type ABSKG-60, control variant 6 (dimensions in mm)

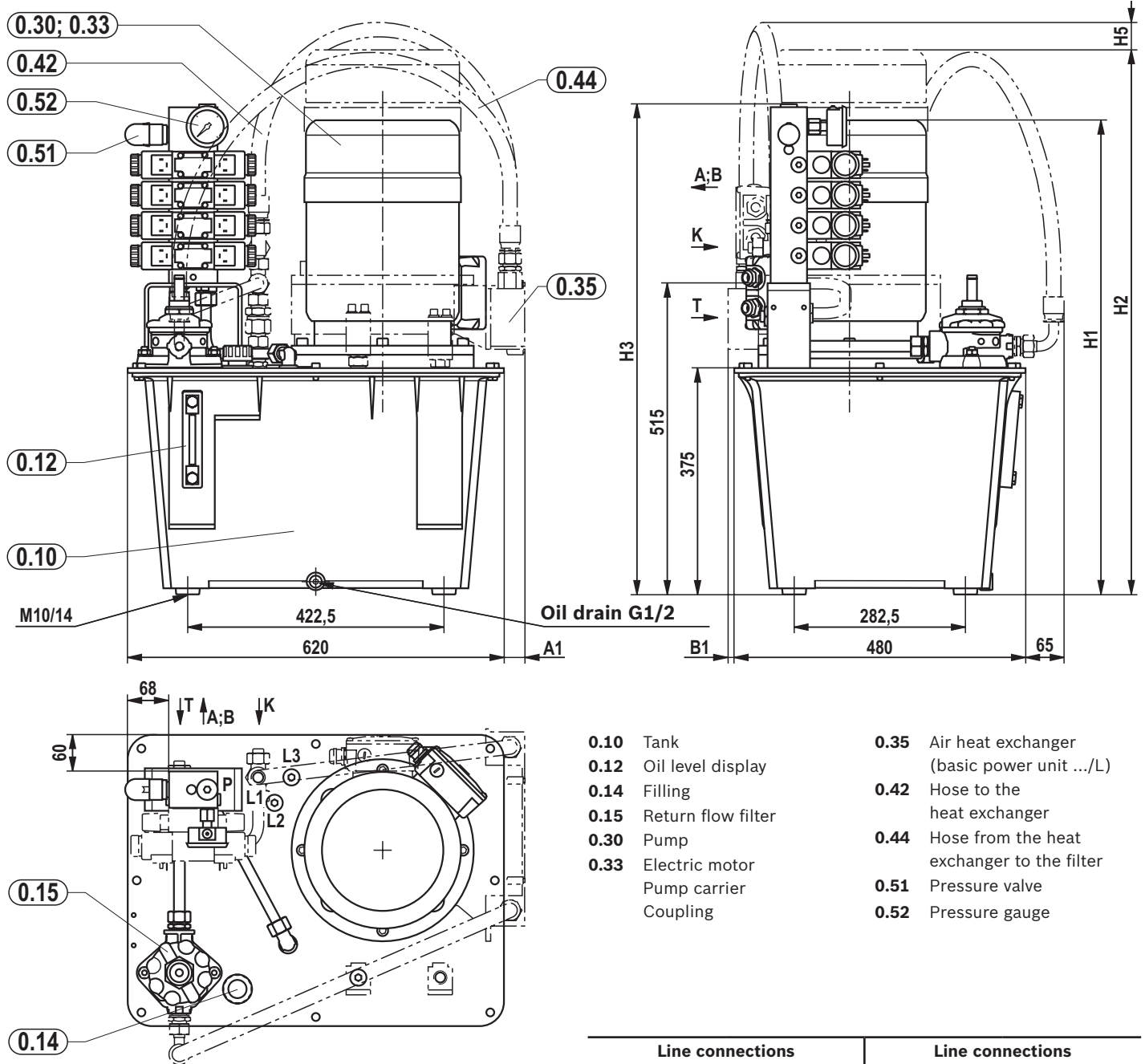

- 0.10 Tank
- 0.12 Oil level display
- 0.14 Filling
- 0.15 Return flow filter
- 0.30 Pump
- 0.33 Electric motor
Pump carrier
Coupling
- 0.35 Air heat exchanger
(basic power unit .../L)
- 0.42 Hose to the
heat exchanger
- 0.44 Hose from the heat
exchanger to the filter
- 0.51 Pressure valve
- 0.52 Pressure gauge

Motor frame size	71	80/90	100/112	132S/132M	
Without air heat exchanger	H1	(607)	(649)/696	740/764	778/816
	A1	-	-	-	35
With air heat exchanger	B1	-	-	-	10
	H2	-	-/777	837/861	894/932
	H5	-	-/85	65/55	55/70

Line connections without air heat exchanger		Line connections with air heat exchanger	
A	G3/8	A	G3/8
B	G3/8	B	G3/8
L3	G1/2	L3	G1/2
P	G1/2	P	G1/2
T (optional)	18L	K (optional)	18L
L1	G1/2	-	-
L2	G3/8	L2	G3/8

Dimensions: Dimension H3

Number of controls	1	2	3	4	5	6	8
H3	658	708	758	808	858	908	1008

Attention: The maximum dimensions may differ due to the attached valves.

Dimensions: Type ABSKG-20, control variant 7 (dimensions in mm)

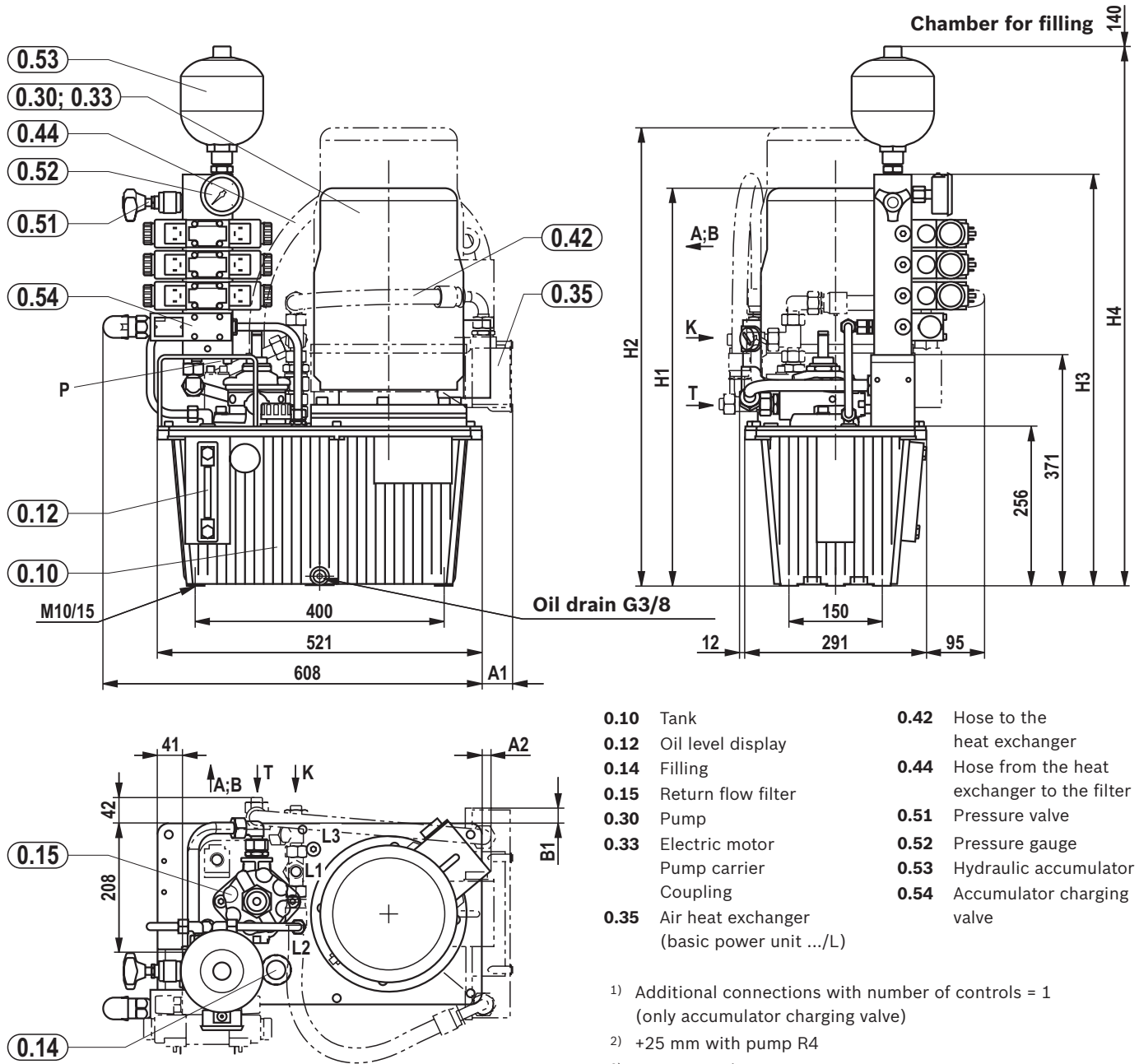

- 0.10** Tank
- 0.12** Oil level display
- 0.14** Filling
- 0.15** Return flow filter
- 0.30** Pump
- 0.33** Electric motor
Pump carrier
Coupling
- 0.35** Air heat exchanger
(basic power unit .../L)
- 0.42** Hose to the
heat exchanger
- 0.44** Hose from the heat
exchanger to the filter
- 0.51** Pressure valve
- 0.52** Pressure gauge
- 0.53** Hydraulic accumulator
- 0.54** Accumulator charging
valve

- 1) Additional connections with number of controls = 1
(only accumulator charging valve)
- 2) +25 mm with pump R4
- 3) +45 mm with pump R4

Motor frame size		71	80/90	100/112
Without air heat exchanger	H1	490	532/579 ²⁾	623 ³⁾ /647
	A2	-	-	-/15
With air heat exchanger	A1	-	-/32	51
	B1	-	-	29
	H2	-	-/660	720/744

Line connections without air heat exchanger		Line connections with air heat exchanger	
A	G3/8	A	G3/8
B	G3/8	B	G3/8
L3	G3/8	L3	G3/8
T (optional) ¹⁾	18L	K (optional) ¹⁾	18L
P	G1/2	P	G1/2
L1	G1/2	-	-

Dimensions: Dimension H3; H4

Number of controls	1	2	3	4	5	6	8
H3	511	561	611	661	711	761	861
H4	717	767	817	867	917	967	1067

Attention: The maximum dimensions may differ due to the attached valves.

Dimensions: Type ABSKG-40, control variant 7 (dimensions in mm)

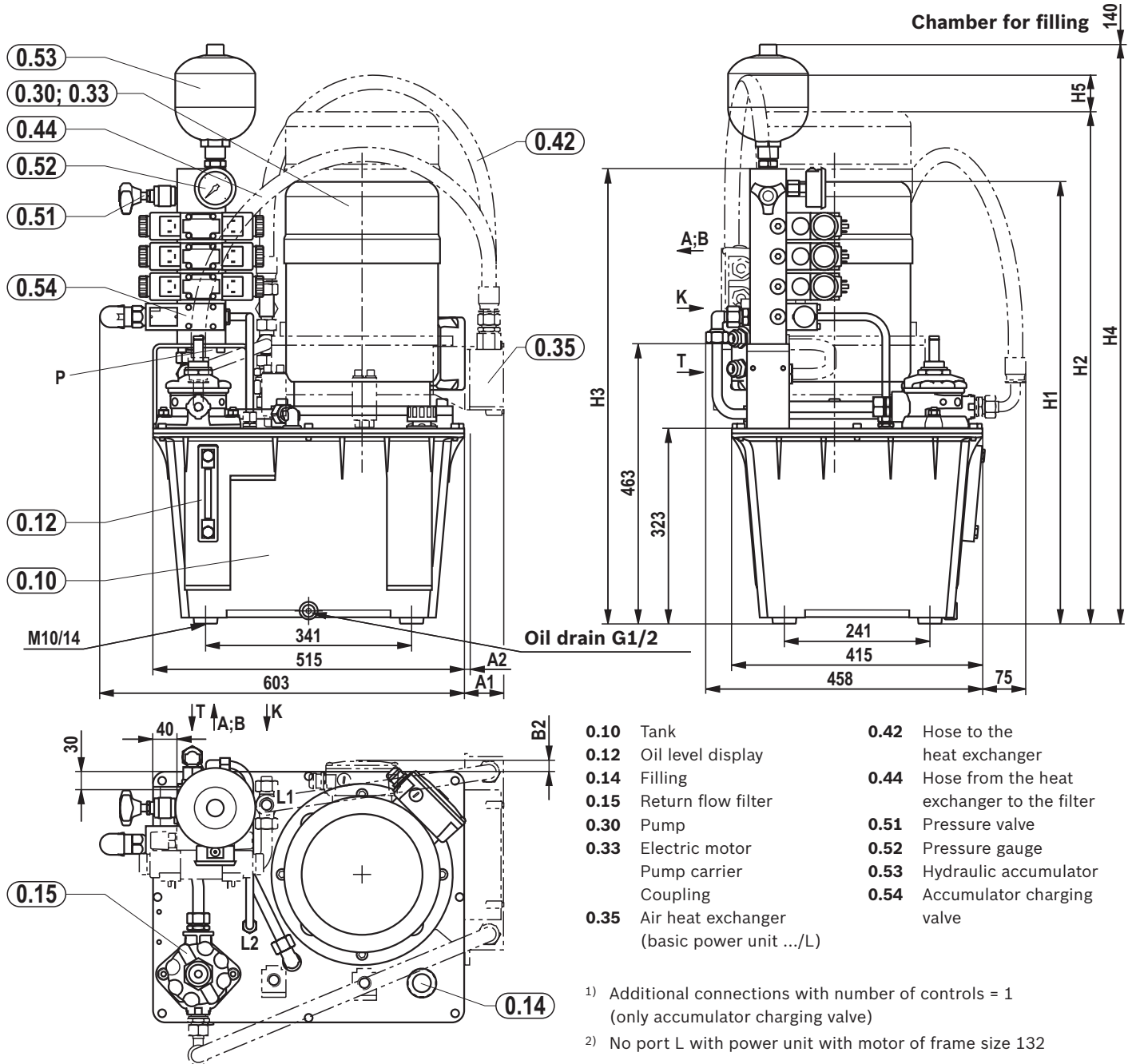

Motor frame size		71	80/90	100/112	132S/132M
Without air heat exchanger	H1	557	599/646	690/714	728/766
	A2	-	-	-/10	-
	B2	-	-	-	20
With air heat exchanger	A1	-	-/31	50	66
	B1	-	-	14	30
	H2	-	-/727	787/811	844/882
	H5	-	-/95	60/60	70/80

Line connections without air heat exchanger		Line connections with air heat exchanger	
A	G3/8	A	G3/8
B	G3/8	B	G3/8
L3 ²⁾	G1/2	L3 ²⁾	G1/2
T (optional) ¹⁾	18L	K (optional) ¹⁾	18L
P	G1/2	P	G1/2
L1	G1/2	-	-

Dimensions: Dimension H3; H4

Number of controls	1	2	3	4	5	6	8
H3	603	653	703	753	803	853	953
H4	809	859	909	959	1009	1059	1159

Attention: The maximum dimensions may differ due to the attached valves.

Dimensions: Type ABSKG-60, control variant 7 (dimensions in mm)

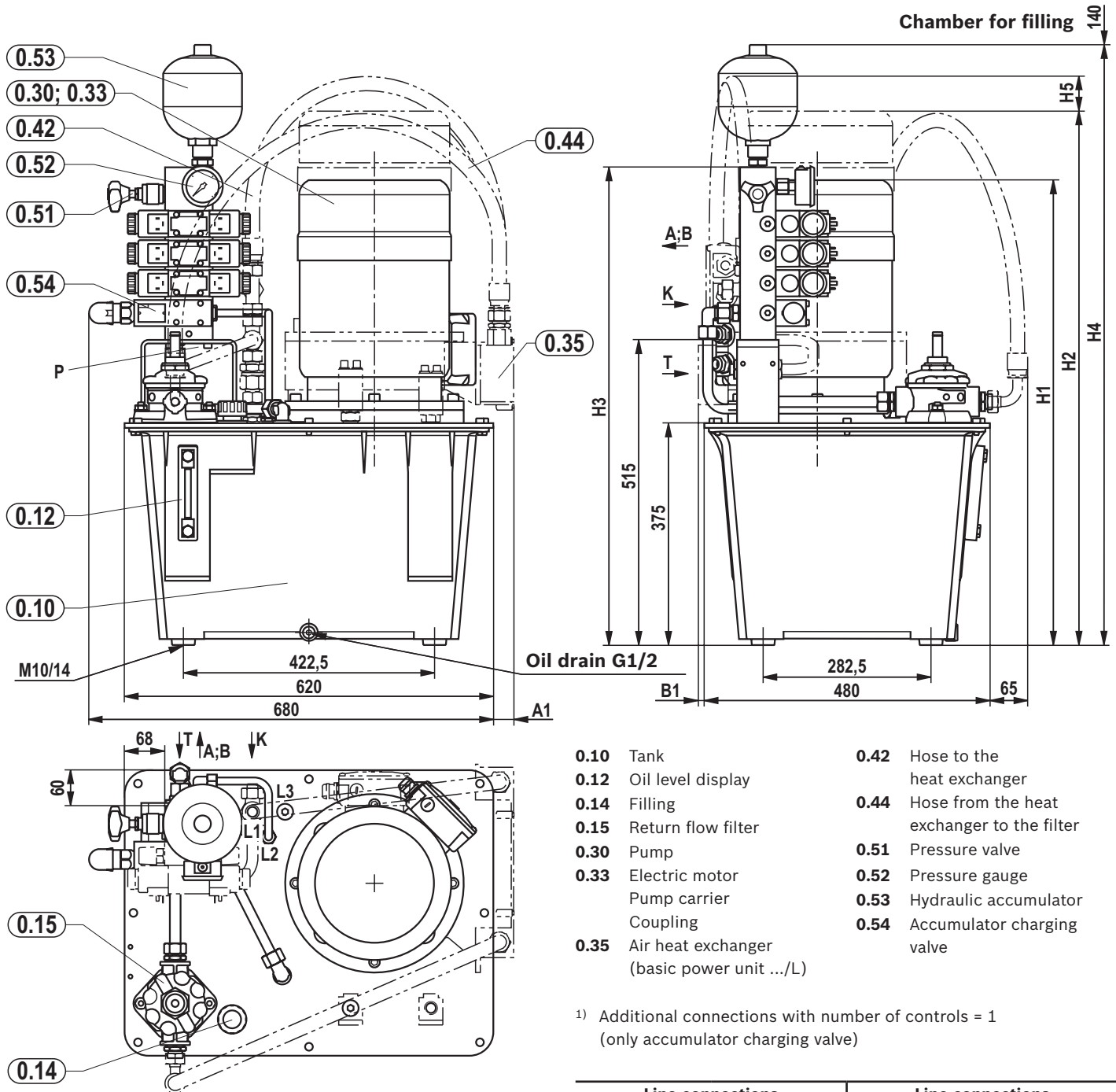

- 0.10** Tank
- 0.12** Oil level display
- 0.14** Filling
- 0.15** Return flow filter
- 0.30** Pump
- 0.33** Electric motor
Pump carrier
Coupling
- 0.35** Air heat exchanger
(basic power unit .../L)
- 0.42** Hose to the
heat exchanger
- 0.44** Hose from the heat
exchanger to the filter
- 0.51** Pressure valve
- 0.52** Pressure gauge
- 0.53** Hydraulic accumulator
- 0.54** Accumulator charging
valve

1) Additional connections with number of controls = 1
(only accumulator charging valve)

Motor frame size	71	80/90	100/112	132S/132M	
Without air heat exchanger	H1 (607)	(649)/696	740/764	778/816	
With air heat exchanger	A1	-	-	35	
	B1	-	-	10	
	H2	-	-/777	837/861	894/ 932
	H5	-	-/95	75/65	65/80

Line connections without air heat exchanger		Line connections with air heat exchanger	
A	G3/8	A	G3/8
B	G3/8	B	G3/8
L3	G1/2	L3	G1/2
T (optional) 1)	18L	K (optional) 1)	18L
P	G1/2	P	G1/2
L1	G1/2	-	-

Dimensions: Dimension H3; H4

Number of controls	1	2	3	4	5	6	8
H3	653	703	753	803	853	903	1003
H4	859	909	959	1009	1059	1109	1209

Attention: The maximum dimensions may differ due to the attached valves.

Options

Level switch N

- Float switch according to data sheet 50212 with **min./max. switching contacts** and optionally with a temperature contact (70 °C)

Tank size	Min. switching point normally closed contact ¹⁾ in mm	Max. switching point normally open contact ¹⁾ in mm	Temperature contact normally closed contact in °C	Type	Material no.
20	120	50	–	ABZMS-35-1X/120F050S-K24	R901057913
40 / 60	165	85	–	ABZMS-35-1X/165F085S-K24	R901057914
20	120	50	70	ABZMS-35-1X/120F050S-T70F-K24	R901057918
40 / 60	165	85	70	ABZMS-35-1X/165F085S-T70F-K24	R901057920

- Float switch according to data sheet 50212 with **min./pre-warning switching contacts** and optionally with a temperature contact (70 °C)

Tank size	Min. switching point normally closed contact ¹⁾ in mm	Switching point (pre-warning) normally open contact ¹⁾ in mm	Temperature contact normally closed contact in °C	Type	Material no.
20	120	90	–	ABZMS-35-1X/120F090S-K24	R901088810
40 / 60	165	135	–	ABZMS-35-1X/165F135S-K24	R901088811
20	120	90	70	ABZMS-35-1X/120F090S-T70F-K24	R901088813
40 / 60	165	135	70	ABZMS-35-1X/165F135S-T70F-K24	R901088814

- Float switch according to data sheet 50220 with **min./pre-warning switching contacts** for level, temperature display and with two programmable temperature switching outputs

Tank size	Min. switching point normally closed contact ¹⁾ in mm	Switching point (pre-warning) normally open contact ¹⁾ in mm	Type	Material no.
20	120	90	ABZMS-40-1X/120F090S-T2-K24	R901245525
40 / 60	165	135	ABZMS-40-1X/165F135S-T2-K24	R901245526

Tank size	Max. filling volume in l	Switching point (pre-warning) in mm	Filling volume at switching point pre-warning in l	Min. switching point in mm	Filling volume at switching point min in l
20	18	90	14	120	11.2
40	33	135	25	165	20.8
60	54	135	43	165	37.0

¹⁾ with decreasing level

For more versions see data sheet 50220

Options

Oil pan O

► The oil pans have been designed to take up the entire tank volume.

Tank size	Oil pan	Material no. assembly steel version	Material no. assembly stainless steel version according to Water Resources Act	Weight in kg
20	AB 40-09/20	R901048242	R901048243	19
40	AB 40-09/40	R901048248	R901048249	23
60	AB 40-09/60	R901048245	R901048246	26

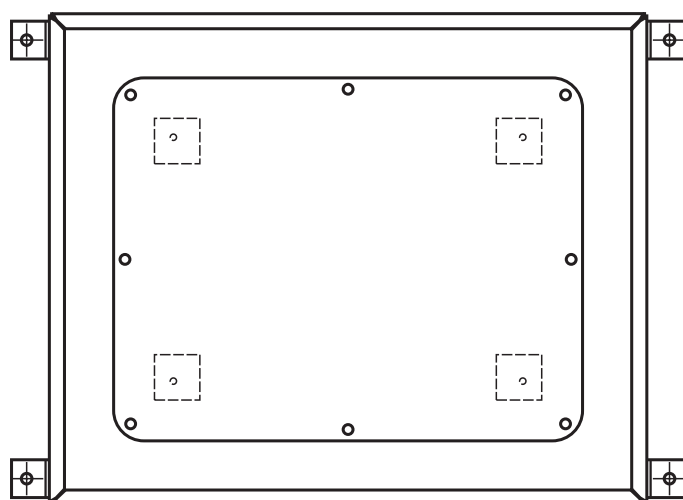
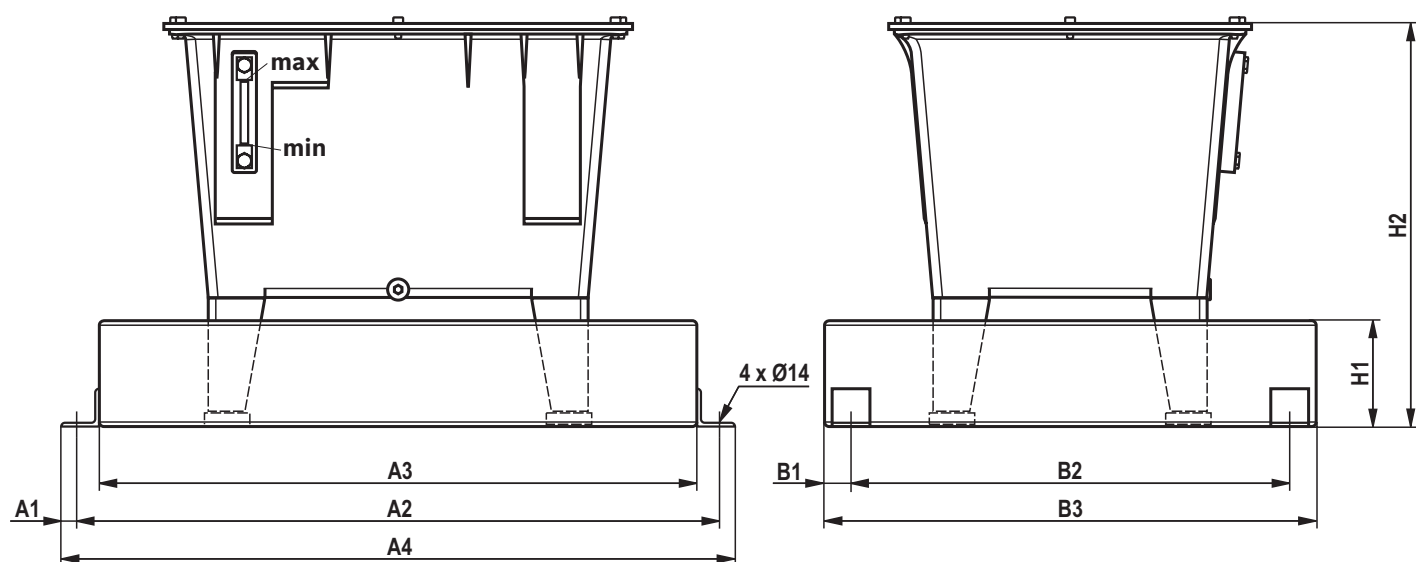

Dimension (dimensions in mm)	Tank size		
	20	40	60
A1	20	20	20
A2	740	750	850
A3	680	690	790
A4	780	790	890
B1	35	35	35
B2	380	520	580
B3	450	590	650
H1	100	140	140
H2	363	483	535

Options

Hand pump P

Assembly kit consisting of:

- ▶ Hand pump AB42-20/25
- ▶ Check valve AB21-12 type RE 12S-0,5 / RE S16-0,5
- ▶ Console

q_{Vmax} in l/min	Tank size	Type	Material no.	Weight in kg
≤ 11.8	20	MONTAGESATZ AB40-09/20-HANDPUMPE <11.8L	R901009181	19
	40	MONTAGESATZ AB40-09/40-HANDPUMPE <11.8L	R901009022	24
	60	MONTAGESATZ AB40-09/60-HANDPUMPE <11.8L	R901009019	29
> 11.8	40	MONTAGESATZ AB40-09/40-HANDPUMPE >11.8L	R901009023	25
	60	MONTAGESATZ AB40-09/60-HANDPUMPE >11.8L	R901009021	30

Hydraulic circuit diagram

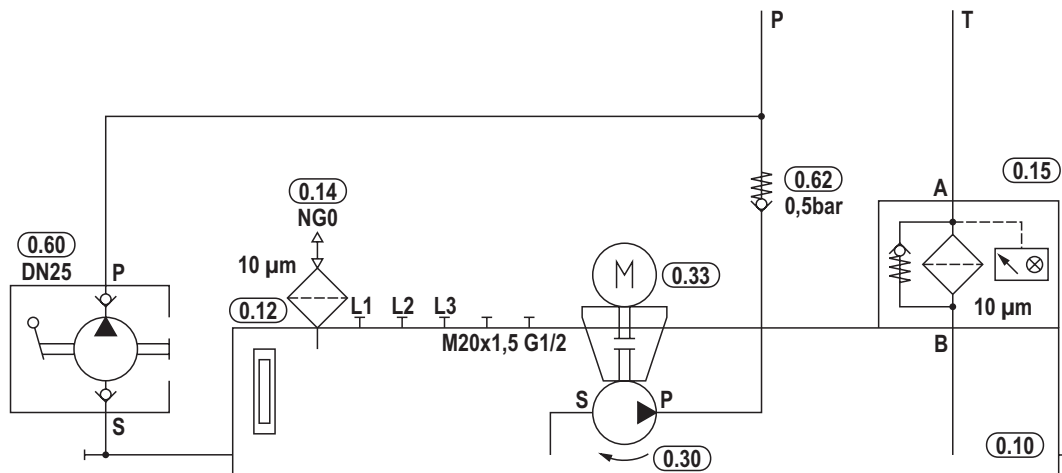

Options

Hand pump P

Dimensions tank size 20

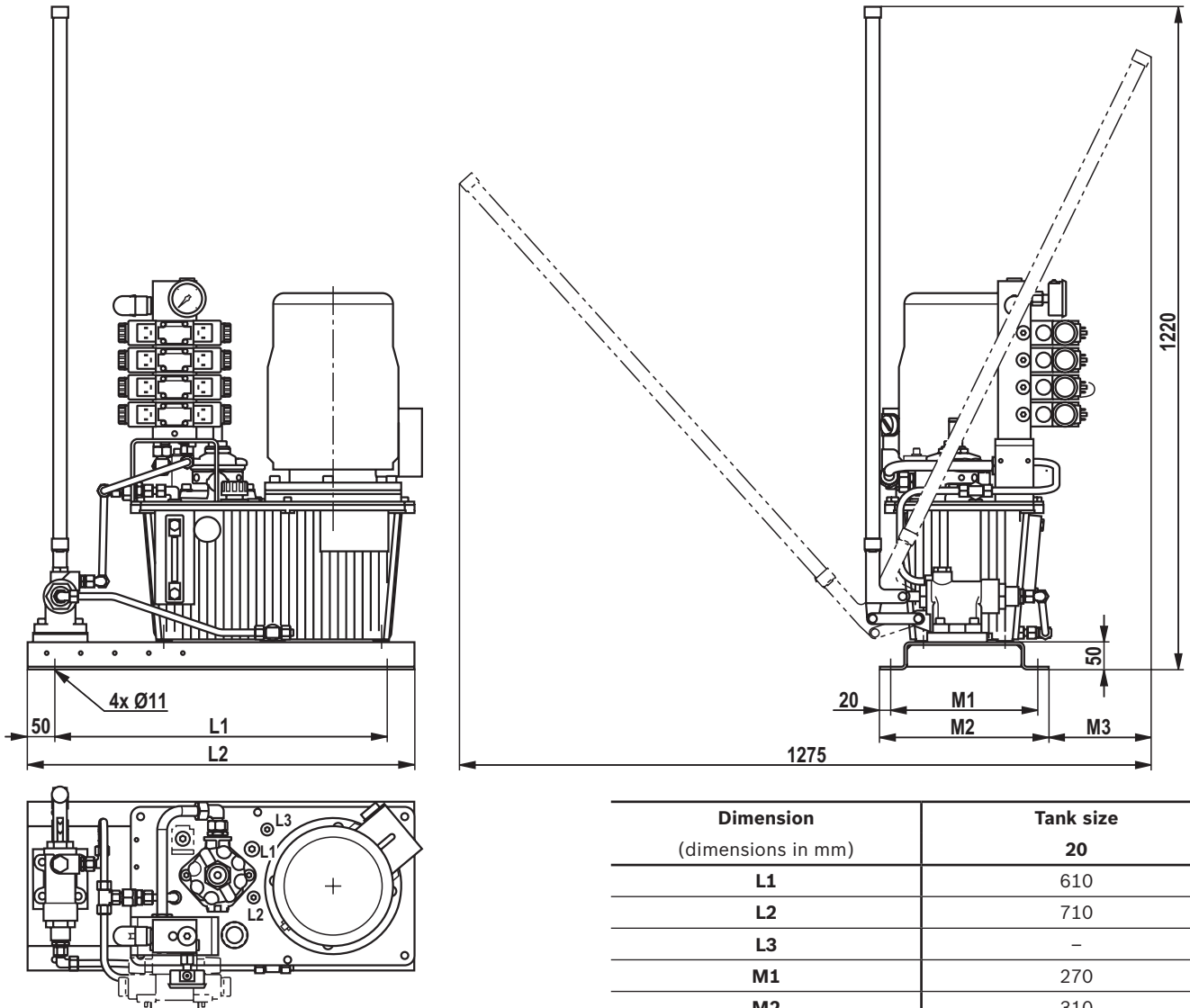

Options hand pump with oil pan on request

Options

Hand pump P

Dimensions tank size 40 l; 60 l

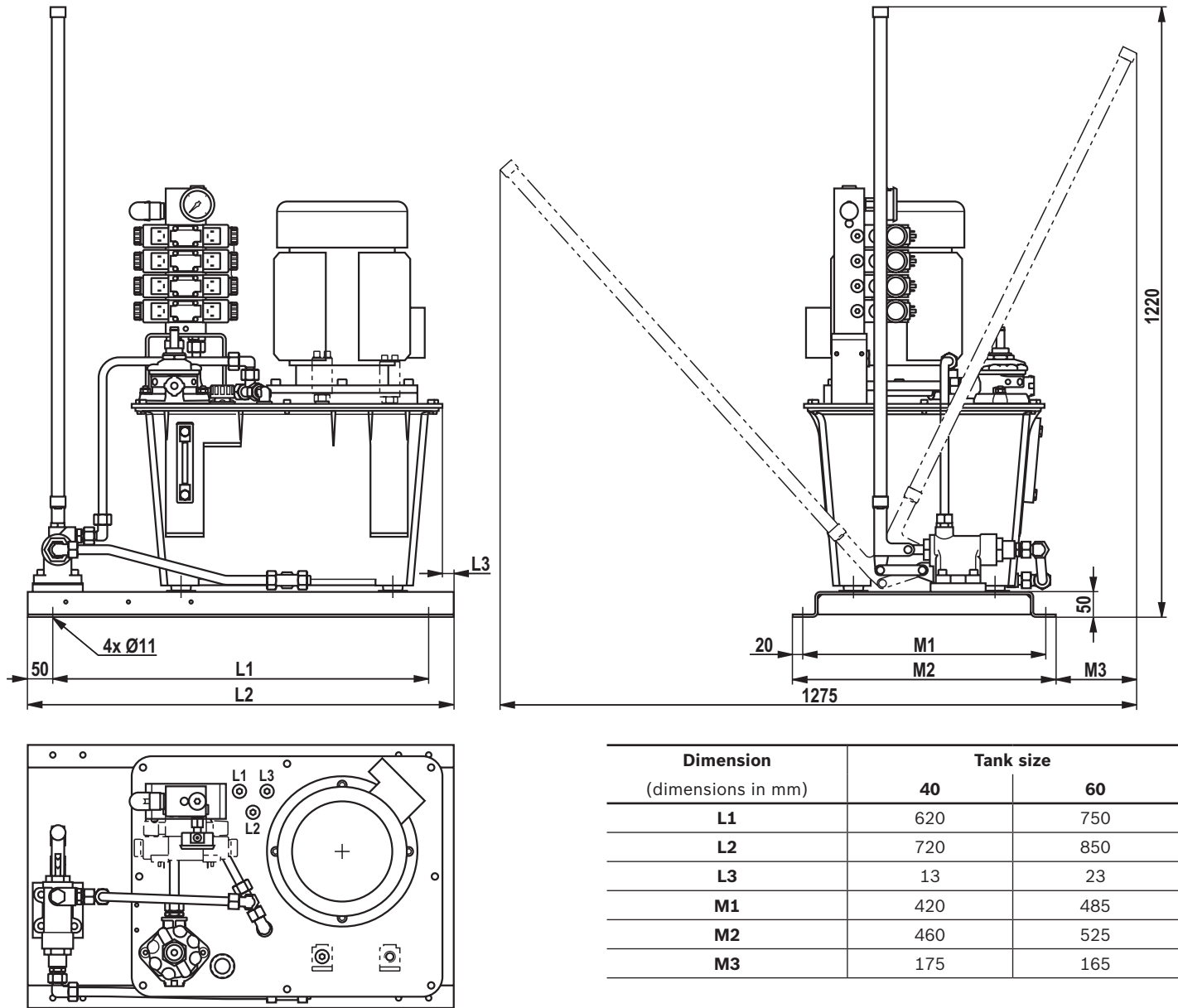

Options hand pump with oil pan on request

Options

Thermostat T

- ▶ Electronic contact thermometer according to data sheet 50224 with directly attached display and control unit and temperature display and two programmable switching outputs

Tank size	Type	Material no.
40 / 60	ABZMT-1X/0300MS/D0-T2-K24	R901247784

- ▶ Electronic contact thermometer according to data sheet 50224 with directly attached display and control unit and temperature display and four programmable switching outputs

Tank size	Type	Material no.
40 / 60	ABZMT-1X/0300MS/D0-T4-K24	R901247785

For more versions see data sheet 50224

More options (e.g. console for pressure filter, accumulator station ABSBG, water heat exchanger) are possible on request.

By default, the power units are supplied without labeling (option).

Complete painting is possible as an option.

Accessories

Maintenance indicator according to data sheet 51450 for return flow filter

- ▶ Electronic switching element for maintenance indicator

Material no.	Type	Signal	Switching points	LED
R928028409	WE-1SP-M12x1	Changeover	1	NO
R928028410	WE-2SP-M12x1	Normally open (at 75 %) / normally closed contact (at 100 %)	2	3 pieces
R928028411	WE-2SPSU-M12x1	Normally closed contact		

For more versions see data sheet 51450

Accessories

Filter replacement element for return flow filter

Tank size	Type	Material no.
20	1.0040 H10XL:A00-O-M	R928005837
40 / 60	1.0063 H10XL:A00-O-M	R928005855

Mating connectors – For detailed information see data sheet 08006

- ▶ Suitable for the listed float switches according to data sheet 50212/50220;
- contact thermometer according to data sheet 50224;
- maintenance indicator for return flow filter according to data sheet 51450

Mating connector for connector K24

Type	Material no.
LEITUNGSDOSE 4P Z24 SPEZ	R900031155

Mating connector for connector K24 with potted-in PVC cable, 3 m long

Type	Material no.
LEITUNGSDOSE 4P Z24M12X1 + 3MSPEZ	R900064381

Foot AB 40-09 for tank 40 l; 60 l

Type	Material no.	Quantity
FUSS AB40-09/1	R901044792	4

Dimension (dimensions in mm)	Tank size	
	40	60
A	381	462.5
B	281	322.5
H	463	515

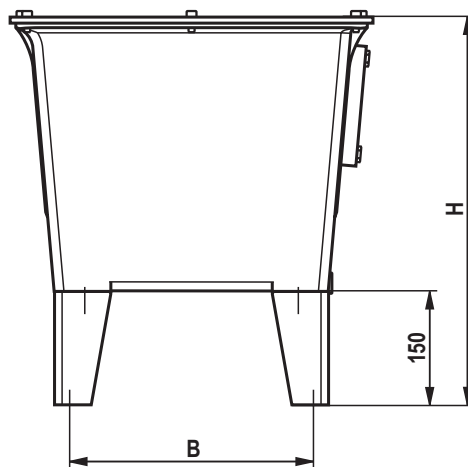
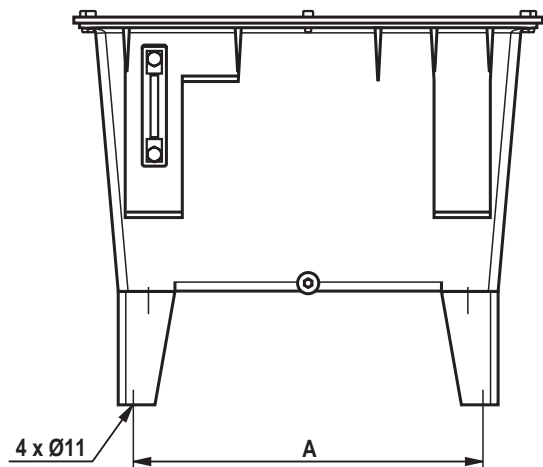

Accessories

Return pipe PN16 for drain lines

Material galvanized steel

Pipe connection according to ISO 8434 part 1

Dimensions (dimensions in mm)

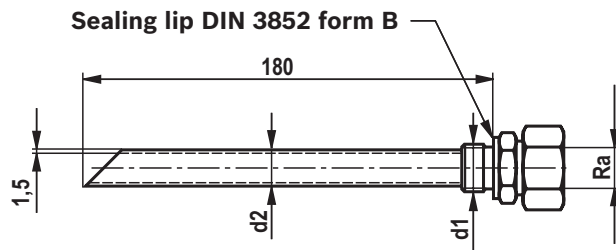

Row	Ra	d1	d2	Material no.
L light	10	G3/8	10	R900086003
	12	G3/8	12	R900064249
	15	G1/2	16	R900064255
	18	G1/2	16	R900064254
S heavy	16	G1/2	16	R900053354

Installation, commissioning, maintenance and operating instructions

Hydraulic power units according to this data sheet are exclusively intended for stationary operation.

They must be installed under low corrosion conditions at a dry indoor climate.

During installation, the power units are to be included in the equipotential bonding. A connection thread M8 marked with the corresponding earthing symbol is located on the tank cover at the mounting bracket of the control.

The power units may only be operated within the performance limits described in this data sheet with the listed operating media.

The power unit must particularly not be operated above the specified operating pressure range and no values above the maximum settings indicated in the circuit diagram must be set at the pressure relief valve.

Warning!

With basic power units without pressure limitation, pressure limitation equipment must be provided in the system, usually a pressure relief valve!

Attention!

Pressure setting upon commissioning with accumulator charging circuits control variant 7!

- ▶ The pressure setting of the pressure cut-off valve DA 6 VA... must at least be 15 bar lower than that of the accumulator safety valve DBDH 6 K1X/...E.

In this connection, please observe the instructions contained in the following documents which are supplied by the factory together with the power unit and must be available upon installation and commissioning:

- ▶ Declaration of incorporation in the sense of the EC Machinery Directive 2006/42/EC, annex II B
- ▶ General assembly instructions with information on the transport of the hydraulic power units, assembly instructions 07009-MON
- ▶ General operating instructions for hydraulic power units and assemblies, data sheet 07009
- ▶ Operating instructions diaphragm type accumulator type HAD (in version with control variant 7), 50150-B
- ▶ Setting instructions pressure relief valve, direct operated type DBD, DBD...-E, 25402-EVT
- ▶ Hydraulic circuit diagram

Notes in the sense of the EC Machinery Directive 2006/42/EC

- ▶ The power units are manufactured in accordance with the harmonized standards DIN EN ISO 4413, DIN EN ISO 12100 and DIN EN 60204-1.
- ▶ The hydraulic power unit constitutes partly completed machinery in the sense of the EC Machinery Directive 2006/42/EC. It is exclusively intended for integration into a machine or system or to be assembled with other components to form a machine or system. The product may be commissioned only if it has been integrated into the machine or system for which it is designed and if the machine or system fully complies with the requirements of the EC Machinery Directive. The hydraulic power unit is not considered to be a safety component in the sense of the EC Machinery Directive 2006/42/EC.

Bosch Rexroth AG
Hydraulics
Zum Eisengießer 1
97816 Lohr am Main, Germany
Phone +49 (0) 93 52/ 18-0
documentation@boschrexroth.de
www.boschrexroth.de

© This document, as well as the data, specifications and other information set forth in it, are the exclusive property of Bosch Rexroth AG. It may not be reproduced or given to third parties without its consent.
The data specified above only serve to describe the product. No statements concerning a certain condition or suitability for a certain application can be derived from our information. The information given does not release the user from the obligation of own judgment and verification.
It must be remembered that our products are subject to a natural process of wear and aging.